

CD36 LOW LEAKAGE CONTROL DAMPER GALVANIZED STEEL

STANDARD CONSTRUCTION

FRAME

5" x 1" x 16 gage (127 x 25 x 1.6) galvanized steel hat channel reinforced with corner braces for structural strength equal to 13 gage (2.28) channel frames. Low profile 3 1/2" x 3/8" x 16 gage (89 x 10 x 1.5) galvanized steel channel top and bottom frame on dampers under 13" (330) high.

BLADES

6" (152) wide, 16 (1.6) gage galvanized steel blades approximately 6" (152) on center. Parallel or opposed action.

SEALS

Blade edge is PVC coated polyester fabric mechanically locked into blade edge. Jamb is flexible metal, compression type.

BEARINGS

Synthetic.

LINKAGE

Concealed in frame. Exposed linkage optional.

AXLES

1/2" (13) plated steel hex.

CONTROL SHAFT

6" (152) x 1/2" (13) diameter. Outboard support bearing supplied with all single section dampers for field mounted actuators. Factory-installed jackshaft supplied with all multiple section dampers.

FINISH

Mill.

MAXIMUM SIZE

Single section – 48"w x 72"h (1219 x 1829).
Multiple section assembly – Unlimited size.

MINIMUM SIZE

Single blade – 5"w x 5"h (127 x 127).
Two blades, parallel or opposed action, exposed linkage – 8"w x 9 5/8"h (203 x 245). (Standard)
Two blades, parallel or opposed action, concealed linkage – 5"w x 8"h (127 x 203). (Optional)

TEMPERATURE LIMITS

-25°F (-32°C) minimum and +180°F (+83°C) maximum.

Maximum section width varies with static pressure. Consult Ruskin if application involves pressures in excess of 2.5 inches w.g. or air velocities in excess of 2000 fpm.

NOTE: Dimensions shown in parenthesis () indicate millimeters.

*Units furnished approximately 1/4" (6) smaller than given opening dimensions.

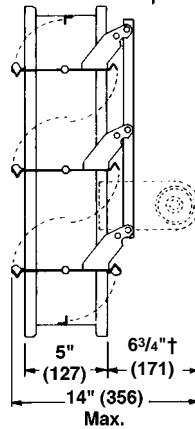
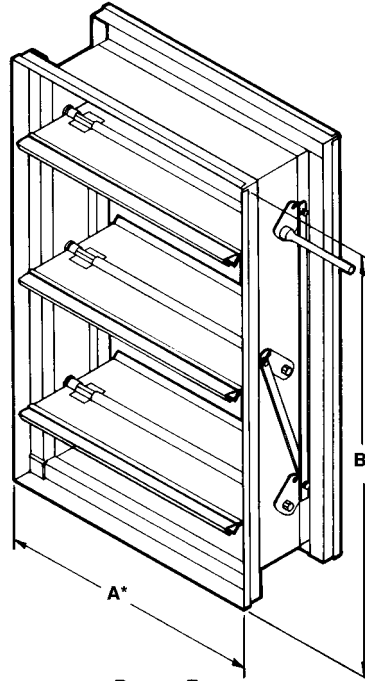

**PARALLEL
BLADE DEPICTED**
Optional Exposed Linkage.

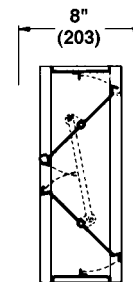

OPPOSED BLADE
Low profile frame illustrated is typical for units under 13" (330) high.

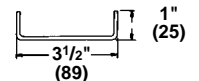

**Heavy Construction/
Special Materials
U-channel Frame Option**

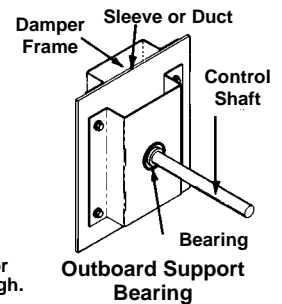

Damper Frame, **Sleeve or Duct**, **Control Shaft**, **Bearing**, **Outboard Support Bearing**

†Jackshaft used only on multiple section dampers.

FEATURES

The CD36 offers sturdy, steel construction with interlocking frame design. Damper locks together without bolts, screws, or rivets that could shake loose. Frame corners are internally braced to reduce racking.

Axles positively lock to blades without screws or welds. Non-stick, noncorrosive bearings assure long life and ease of operation. Axles and bearings combine with a shake proof linkage for low maintenance operation.

When tested in accordance with AMCA Standard 500, the reasonably priced CD36 also exhibits low leakage rates that meet the frequently specified, 10 cfm/sq. ft. at 4" w.g. level.

VARIATIONS

Variations to the CD36 basic design are available at additional cost. They include:

- Enamel and epoxy finishes.
- Factory-installed, pneumatic and electric actuators (specific information required with order).
- Ruskin frame-mounted universal actuator bracket to simplify field installation of most actuators (specify actuator and action, i.e., N.O. or N.C., with order).
- SP100 Switch Package to remotely indicate damper blade position.
- Heavier frame construction with U-channel frame.
- Front, rear or double flange frame with or without bolt holes.
- 304 stainless steel construction.

QTY.	OPENING DIM.		BLADE ACTION		FRAME STYLE			VARIATIONS
	A*	B*	PB	OB	STD.	Front Flange FF	Rear Flange RF	

**JOB
CONTRACTOR**

LOCATION

CD36 PERFORMANCE DATA

Damper Width	Maximum System Pressure	Maximum System Velocity	Leakage*	
			% of max. flow	CFM/sq. ft.
48"	2.5" w.g.	1500 fpm	0.36	3.7
36"	3.0" w.g.	1500 fpm	0.36	3.7
24"	4.0" w.g.	1500 fpm	0.39	4.8
12"	5.0" w.g.	1500 fpm	0.47	7.0

*Leakage information based on pressure differential of 1" w.g. tested per AMCA Publication 500.

INSTALLATION

CD36 IS NOT RECOMMENDED FOR INSTALLATION WITH BLADES RUNNING VERTICALLY. For proper installation, damper must be installed square and free from racking. Actuator must be installed on linkage side. Opposed blade dampers must be operated from a power blade or shaft. See "Induct Mount Control Dampers Installation Instructions" for details.

BRACING OF MULTIPLE SECTION DAMPER ASSEMBLIES

The CD36 is intended to be self supporting only in its largest single section size. Multiple section damper assemblies may require bracing to support the weight of the assembly and to hold against system pressure. Ruskin recommends appropriate bracing to support the damper horizontally at least once for every 8' of damper width. Vertical assemblies and higher system pressures may require more bracing.

CD36 SUGGESTED SPECIFICATION

Furnish and install, at locations shown on plans, or in accordance with schedules, control dampers that meet the following minimum construction standards. Frame shall be 16 gage (1.6) galvanized steel structural hat channel with tabbed corners for reinforcement. The blades shall be single skin, 16 gage (1.6) galvanized steel with three longitudinal grooves for reinforcement. Blade edge seals shall be PVC coated polyester fabric suitable for -25°F to +180°F mechanically locked into the blade edge. Adhesive or clip-on type seals are unacceptable. Jamb seals shall be flexible metal, compression type to prevent leakage between blade end and damper frame. Blade end overlapping frame is unacceptable. Bearings shall be corrosion resistant, molded synthetic sleeve type turning in an extruded hole in the damper frame. Axles shall be hexagonal positively locked into the damper blade. Linkage shall be concealed

out of airstream, within the damper frame to reduce pressure drop and noise. Submittal must include leakage, pressure drop, maximum velocity and maximum pressure data based on AMCA Publication 500. Dampers shall be in all respects equivalent to Ruskin Model CD36.

Specifier Select Option

Dampers shall be equipped with factory installed damper position indication switch package. The switch package shall include two position indication switches linked directly to the damper blade to provide full open and full closed damper blade position. The switch package shall provide the capability to interface with the HVAC control system and provide remote damper blade position status. Switch packages shall be in all respects equivalent to Ruskin Model SP-100.

RUSKIN®

3900 Dr. Greaves Rd.
Kansas City, MO 64030
(816) 761-7476
FAX (816) 765-8955