

BLOWERS/MOTORS/DRIVES

The blower, motor and drive assembly is what causes air to move through the supply fan. There are many factors that must be considered when discussing these components. The motor, pulleys, belts and blower are components that make up this assembly and they are discussed below:

MOTOR PULLEY ADJUSTMENT

The adjustable motor pulley is factory set for the RPM specified. Speed can be increased by closing or decreased by opening the adjustable motor sheave. Two groove variable pitch pulleys must be adjusted an equal number of turns open or closed. Any increase in speed represents a substantial increase in horsepower required by the unit. Motor amperage should always be checked to avoid serious damage to the motor when the speed is varied.

PULLEY ALIGNMENT

Pulley alignment is adjusted by loosening the motor pulley or driven pulley set screws and moving the pulley on the shaft. See Fig. 1. A straight edge should be used when aligning pulleys.

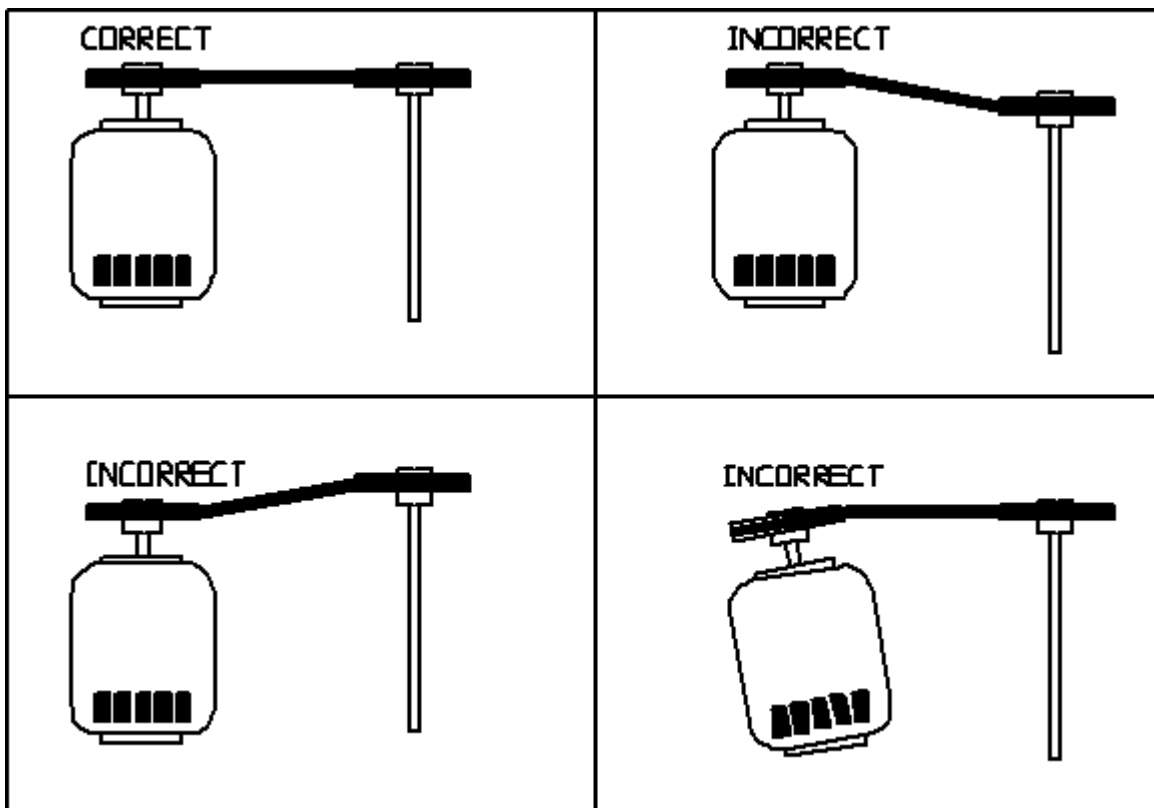

Figure 1

BELT TENSION

Belt tension should be checked after the first 48 hours of fan operation. Do not tension belts by changing the setting of the motor pulley, this will change the fan speed and may damage the motor. To re-tension belts, with the power to the fan motor OFF. Loosen the fasteners that hold the motor mount to the blower. Rotate the motor to the left or right to adjust the belt tension. Belt tension should be adjusted to allow 1/64" of deflection per inch of belt span. See Fig. 2. Exercise extreme care when adjusting V-belts as not to misalign pulleys. Any misalignment will cause a sharp reduction in belt life and produce squeaky noises. Overtightening will cause excessive belt and bearing wear as well as noise. Too little tension will cause slippage at startup and uneven wear. **Whenever belts are removed or installed, never force belts over pulleys without loosening motor first to relieve belt tension.**

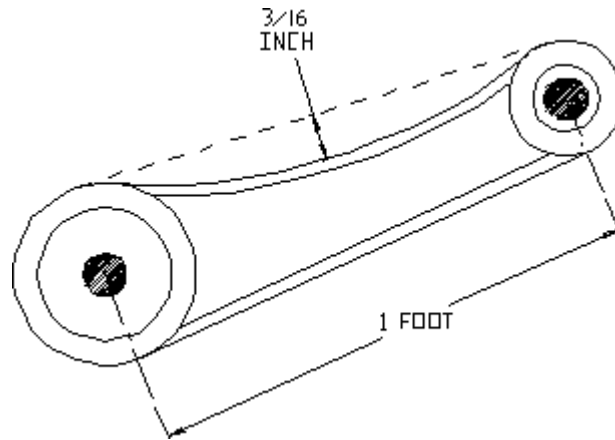

Figure 2

MAINTENANCE

WARNING: DO NOT ATTEMPT MAINTENANCE ON THE FAN UNTIL THE ELECTRICAL SUPPLY HAS BEEN COMPLETELY DISCONNECTED.

1. Fan inlet and approaches to ventilator should be kept clean and free from any obstruction.
2. Motors are normally permanently lubricated. Check bearings periodically, if they have grease fittings lubricate each season. Use caution when lubricating bearings, wipe the fittings clean, the unit should be rotated by hand while lubricating.
Caution: Use care when touching the exterior of an operating motor. Motors normally run hot and may be hot enough to be painful or cause injury.
3. Belt tension should be checked after two days of fan operation and each season thereafter. See instructions elsewhere in this manual. Over-tightening will cause excessive bearing wear and noise. Too little tension will cause slippage at startup and uneven wear.
4. Blowers require very little attention when moving clean air. Occasionally oil and dust may accumulate causing imbalance. If the fan is installed in a corrosive or dirty atmosphere, periodically inspect and clean the wheel, inlet and other moving parts to ensure smooth and safe operation.
5. All fasteners should be checked for tightness each time maintenance checks are performed prior to restarting unit.
6. Filters need to be cleaned and washed semi annually, more often in severe conditions.

BLOWER/MOTOR TROUBLESHOOTING CHART

Problem	Potential Cause
Fan Inoperative	<ul style="list-style-type: none">• Disconnect switch in "Off" position. Turn to "On" position.• Motor wired incorrectly. Check motor wiring to wiring diagram located on fan motor.• Open circuit breaker or overload in starter set too low. Reset circuit breaker or check setting of overload.
Insufficient Air or Pressure	<ul style="list-style-type: none">• Fan rotating in the wrong direction. Be sure fan is rotating in the direction shown on rotation label.• Poor outlet conditions. There should be a straight clear duct at the outlet.• Open circuit breaker or overload in starter set too low. Reset circuit breaker or check setting of overload.
Excessive Vibration and Noise	<ul style="list-style-type: none">• Belts too loose, worn or oily. Inspect and replace if needed.• Misaligned pulleys. Refer to "Pulley Alignment" section.• Fan speed is too high. Refer to "Motor Pulley Adjustment" section.• Fan rotating in the wrong direction. Be sure fan is rotating in the direction shown on rotation label.• Bearings need lubrication or replacement.• Damaged or unbalanced wheel.• Fan is operating in the unstable region of the fan curve.
Motor Overload	<ul style="list-style-type: none">• Fan rotating in the wrong direction. Be sure fan is rotating in the direction shown on rotation label.• Fan speed is too high. Refer to "Motor Pulley Adjustment".• Motor wired incorrectly. Check motor wiring to wiring diagram located on fan motor.• Overload in starter set too low

A.O. SMITH MOTOR INFORMATION CHART

Single Phase Motors

Horsepower	Voltage	FLA	Shaft Size (IN)
0.25	115/230	4.6/2.3	.5
0.33	115/230	6.0/3.0	.625
0.5	115/230	8.8/4/4	.625
0.75	115/230	10.4/5.2	.625
1	115/230	15.4/7.7	.625
1.5	115/230	20.0/10.0	.625
2	115/230	26.0/13.0	.875
3	115/230	31/15.5	1.125
5	230	22	1.125

Three Phase Motors

Horsepower	Voltage	FLA	Shaft Size (IN)
0.5	200-230/460	2.6/1.3	.625
0.75	200-230/460	3.1/1.6	.625
1	200-230/460	3.6/1.8	.625
1.5	200-230/460	5.8/2.9	.625
2	200-230/460	6.0/3.0	.625
3	200-230/460	8.6/4.3	.875
5	208-230/460	14.8-14.0/7.0	1.125
7.5	208-230/460	25.0-19.2/9.6	1.375
10	200-230/460	29.3-25.8/12.9	1.375
15	200-230/460	43.2-38.6/19.3	1.625
20	200-230/460	56-49.6/24.8	1.625

DELHI BLOWER INFORMATION CHART

Blower Model	Wheel Diameter (IN)	Shaft Size (IN)
G10	10	0.75
G12	12	1
G15	15	1
G18	18	1.875
920	20	1.4375
925	25	2.1875