

Model R-NDI - Island Hood with Make-Up Air



The R-NDI Hood efficiently meets the challenges of any island style cooking application. The perforated supply plenum accessory provides up to 90% make-up air.

Features at a Glance



- ETL Listed and NSF Listed Product
- Superior Exhaust Flow Rates
- Exceptional Capture and Containment of Cooking Vapors
- Island Configuration
- Front Design Directs Air into Filters
- Stainless Steel Construction
- Double Wall, Insulated Front
- Heavy Duty Grease Baffle Filters
- Grease Drain System
- Pre-punched Hanging Angles
- Factory Pre-wired Lighting Optional
- Face Mounted Controls Optional
- Front Make-Up Air (PSP Accessory) Featuring
 - 90% Air Delivery with a Maximum of 200 CFM/ft
 - Low Discharge Velocities
 - Directs Air into Hood's Capture Area
 - Even Distribution Across Length of Hood
 - Stainless Steel Construction to Match Hood

Optional Equipment

- Utility Cabinet
- Fire Suppression System
- Electrical Controls
- Integral Clearance to Combustibles System
- UL Listed Exhaust Fire Damper
- Supply Fire and/or Volume Damper Assembly
- Enclosure Panels to Ceiling
- End Panels
- Type 304 Stainless Steel Construction
 - Exposed Surfaces Only
 - 100% Construction
- Filters
 - High Velocity Cartridge Filters
 - Stainless Steel Baffle Type
- Lighting
 - Recessed Incandescent
 - Recessed Fluorescent
- Roof Top Package
- Separate Exhaust and/or Make-Up Air Fans
- Heated Make-Up Air Units
 - Direct Gas Fired Heated Make-Up Air Fans
 - Indirect Gas Fired Heated Make-Up Air Units

Performance Data

Max. Avg. Cooking Surface Temp (F°) - Cooking Surfaces	Min. Exhaust CFM / ft	Max. Suggested Supply CFM / ft via Front Supply Plenum
<i>400°F – Oven, Steamers, Kettles, Open-Burner Ranges, Griddles, Fryers</i>	346	314
<i>600°F – Gas Charbroilers, Electric Charbroilers</i>	422	380
<i>700°F – Mesquite Grills, Charcoal Charbroilers, Gas Conveyor Charbroilers</i>	475	400

• Exhaust based on 1500 FPM; Supply based on 800 FPM

Sectional View

R-NDI with Make-Up Air

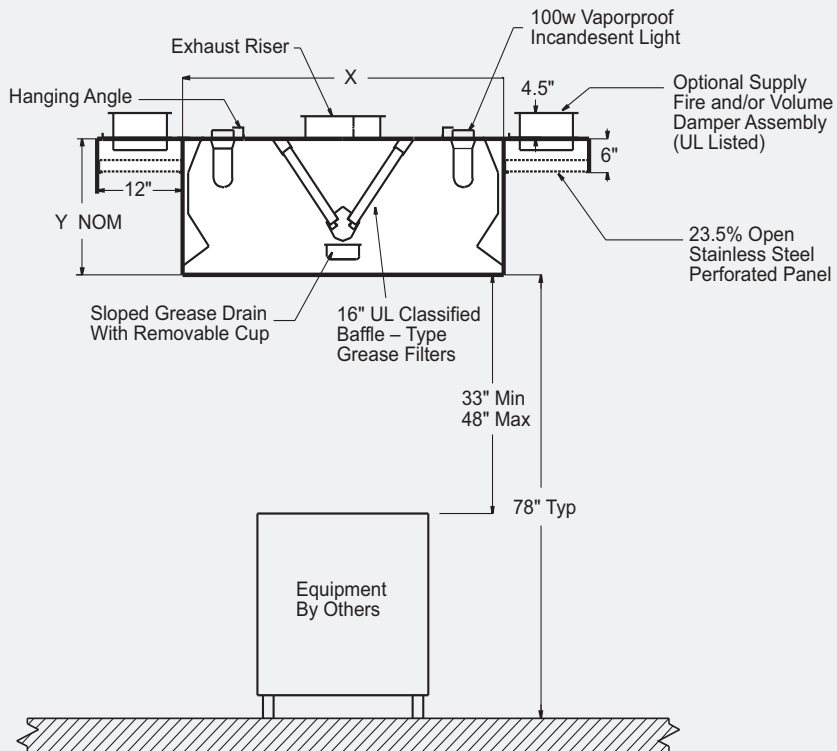

Please visit us at www.ruppams.com