

MODULAR OUTDOOR DOWN DISCHARGE ELECTRIC HEATER PACKAGED UNIT WITH COOLING AND INTAKE HOOD

IHS&ACCP-HPV-15
REV.4.3 06/15/2015

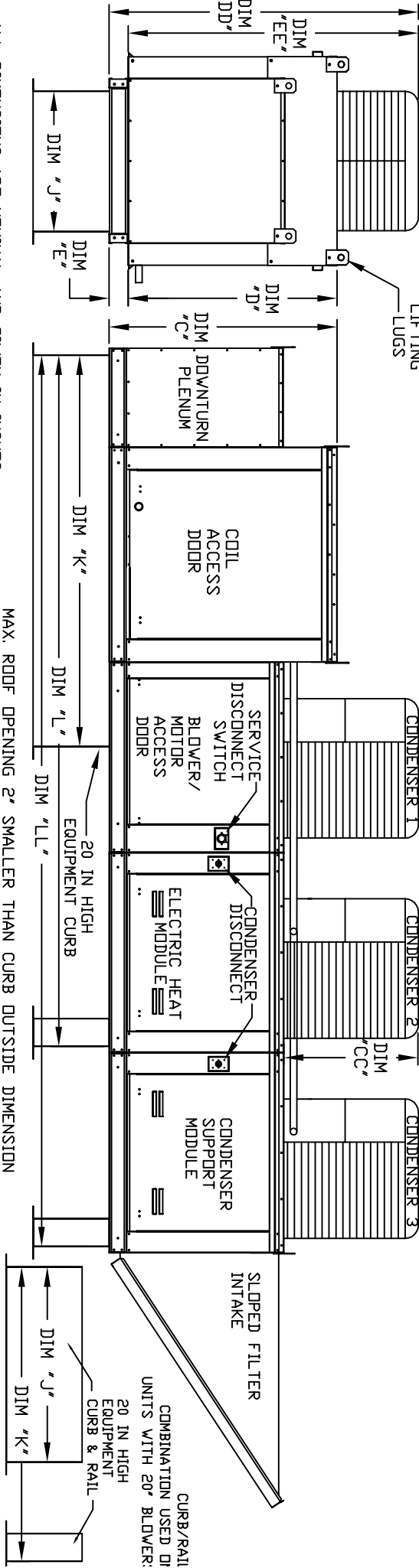
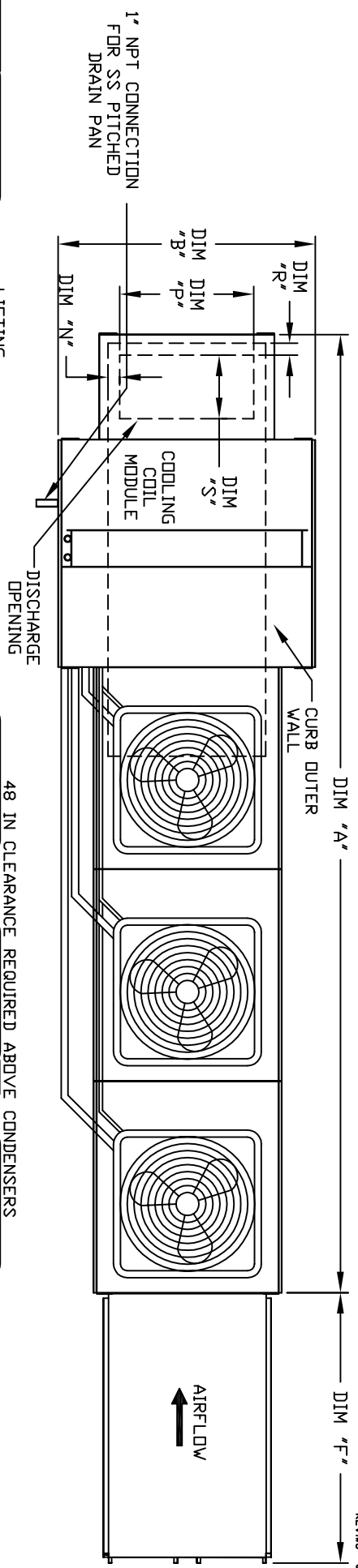

MAX. ROOF OPENING 2' SMALLER THAN CURB OUTSIDE DIMENSION

ALL DIMENSIONS ARE NOMINAL AND GIVEN IN INCHES.

| MODEL | WEIGHT | A | B | C | D | E | F | J | K | L | LL | N | P | R | S |
|--------|----------|---------|---------|--------|--------|-------|--------|----|----------|-----------|---------|--------|--------|---------|--------|
| E3-G18 | 1630 LBS | 196-1/4 | 54-3/8 | 56-3/8 | 51-1/8 | 5-1/4 | 51-5/8 | 35 | 84 | 150-5/8 | 192-7/8 | 6-5/16 | 22-3/8 | 1-1/2 | 18 |
| E4-920 | 2640 LBS | 257-1/2 | 60-7/16 | 64-3/8 | 59-1/8 | 5-1/4 | 76-3/8 | 42 | 115-3/16 | 199-13/16 | 254-1/8 | 5-1/4 | 31-1/2 | 1-13/16 | 23-1/2 |

UNIT INFORMATION

| MODEL | TONNAGE RANGE | FILTER SIZE & QTY | MAX. FILTER VELOCITY |
|--------|---------------|-------------------|----------------------|
| E3-G18 | 15 Ton | 16"x20"x2" (6) | @8000 CFM = 762 FPM |
| E4-920 | 15 Ton | 16"x20"x2" (10) | @13000 CFM = 743 FPM |

*ADD CONDENSING UNIT WEIGHT TO WEIGHT IN TABLE ABOVE

CONDENSER INFORMATION

| MODEL | WEIGHT* | #1 | #2 | #3 | CC | DD | EE |
|------------|---------|-------|-------|-------|----------|---------|----------|
| 15 TON-G18 | 591 LBS | 5 TON | 5 TON | 5 TON | 32-13/16 | 76-3/16 | 70-7/8 |
| 15 TON-920 | 591 LBS | 5 TON | 5 TON | 5 TON | 32-13/16 | 97-3/16 | 91-15/16 |

DATA DERIVED FROM