

MODULAR OUTDOOR DOWN DISCHARGE ELECTRIC HEATER-ROOF TOP PACKAGE WITH COOLING, LPD EVAPORATIVE COOLER INTAKE AND INTAKE HOOD

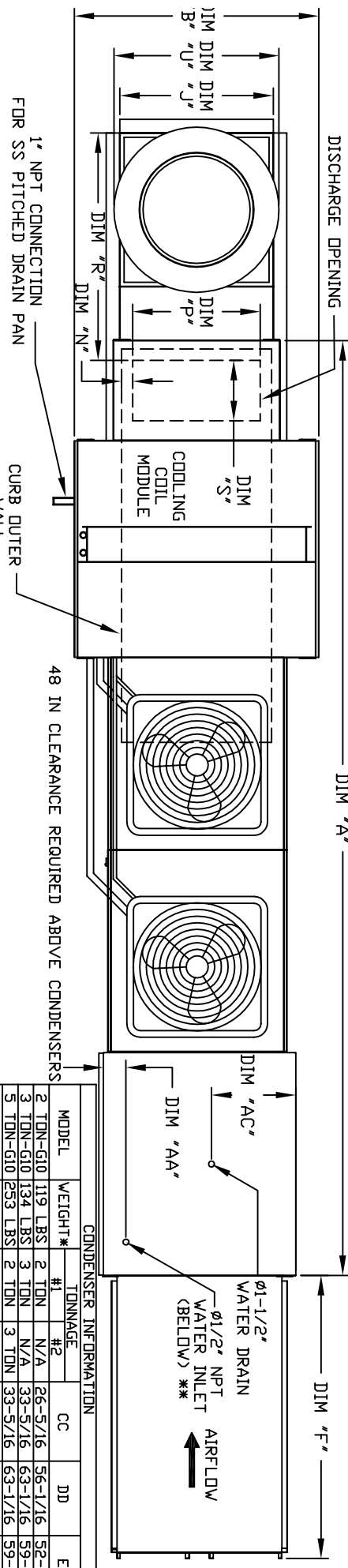

CONDENSER INFORMATION

MODEL	WEIGHT*	#1	#2	CC	DD	EE
2 TON-G10	119 LBS	2 TON	N/A	26-5/16	56-1/16	52-3/8
3 TON-G10	134 LBS	3 TON	N/A	33-5/16	63-1/16	59-3/8
5 TON-G10	253 LBS	2 TON	3 TON	33-5/16	63-1/16	59-3/8
5 TON-G10	302 LBS	2.5 TON	2.5 TON	32-13/16	62-9/16	58-7/8
5 TON-G15	197 LBS	5 TON	N/A	32-13/16	69-9/16	65-7/8
7.5 TON-G15	348 LBS	2.5 TON	5 TON	32-13/16	69-9/16	65-7/8
8 TON-G15	331 LBS	3 TON	5 TON	33-5/16	71-1/16	68
10 TON-G15	394 LBS	5 TON	5 TON	32-13/16	69-9/16	65-7/8
10 TON-G18	394 LBS	5 TON	5 TON	32-13/16	76-3/16	70-7/8
10 TON-G20	394 LBS	5 TON	5 TON	32-13/16	97-3/16	91-15/16

EXHAUST UNIT DIMENSIONS

MODEL #	T	U	V ***
BDU2	14-1/2	22	19
BDU11			
BDU15	18-1/2	27-1/4	21
BDU20			
BDU23			
BDU24			
BDU25			
BDU26			
BDU27			
BDU28	23-1/2	39-3/8	28
BDU29	29-1/2	38-7/8	28
BDU30	30-5/8	43-3/8	33
BDU31			
BDU32			
BDU33			
BDU34			
BDU35			
BDU36			
BDU37			
BDU38			
BDU39			
BDU40			
BDU41			
BDU42			
BDU43			
BDU44			
BDU45			
BDU46			
BDU47			
BDU48			
BDU49			
BDU50			
BDU51			
BDU52			
BDU53			
BDU54			
BDU55			
BDU56			
BDU57			
BDU58			
BDU59			
BDU60			
BDU61			
BDU62			
BDU63			
BDU64			
BDU65			
BDU66			
BDU67			
BDU68			
BDU69			
BDU70			
BDU71			
BDU72			
BDU73			
BDU74			
BDU75			
BDU76			
BDU77			
BDU78			
BDU79			
BDU80			
BDU81			
BDU82			
BDU83			
BDU84			
BDU85			
BDU86			
BDU87			
BDU88			
BDU89			
BDU90			

UNIT DIMENSIONS

MODEL	A	B	C	D	E	F	J	K	L	M	N	P	R	S	AA	AB	AC	AD	INTAKE FILTER SIZE & QTY	MAX. FILTER VELOCITY
E1-G10	167-1/4	39-3/8	42-3/4	39	3-3/4	53-5/8	21	71	106	166-5/8	3-9/16	13-7/8	36-13/16	11-1/2	4-1/2	6-1/4	18	16	20"x25"x2" (3)	63600 CFM = 417 FPM
E2-G15	187-1/4	49-3/8	47-3/4	44	3-3/4	51-5/8	31	79	124	190-5/8	4-5/16	22-3/8	46-9/16	18	4-1/2	5-3/4	20	19	16"x20"x2" (6)	65900 CFM = 419 FPM
E3-G18	189-3/8	54-3/8	56-3/8	51-1/8	5-1/4	76-3/8	35	84	133	199-5/8	6-5/16	22-3/8	49-1/2	18	4-1/2	5-3/4	23-1/2	17-1/2	16"x20"x2" (10)	68000 CFM = 457 FPM
E4-920	238-9/16	60-7/16	64-3/8	59-1/8	5-1/4	71-3/8	42	115-3/16	171-3/16	235-13/16	5-1/4	31-1/2	56-13/16	23-1/2	4-1/2	5-3/4	28-7/8	17-1/2	20"x25"x2" (8)	613000 CFM = 565 FPM

UNIT INFORMATION

MODEL	TONNAGE RANGE	TOT. WEIGHT	MEDIA SIZE & QTY	VEL. & MAX. CFM (NOZZLES)	MAX. FLOW RATE
E1-G10	2 Ton	1180 LBS	25"x32"x12" 5	648 FPM	20
E2-G15	5 Ton	1605 LBS	30"x36"x12" 8	867 FPM	28
E3-G18	10 Ton	2040 LBS	38"x43"x12" 12	705 FPM	35
E4-920	10 Ton	3005 LBS	45"x54"x12" 12	770 FPM	42

CELDEX EVAPORATIVE COOLING UNIT

*** 9 INCH HIGH EXHAUST ADAPTER MAY BE REQUIRED

20 IN HIGH EQUIPMENT CURB

CURB/RAIL COMBINATION USED ON UNITS WITH 20" BLOWERS

1-1/2" DN SUPPRT LEG

E2 UNITS ONLY

SLOPED FILTER INTAKE

**ADD CONDENSING UNIT WEIGHT TO WEIGHT IN TABLE ABOVE

** MAX EVAP WATER PRESSURE = 50 PSI @ 70 DEG F

ALL DIMENSIONS ARE NOMINAL AND GIVEN IN INCHES.

MAY DIFFER Slightly FROM MANUFACTURER'S DIMENSIONS