

MODULAR OUTDOOR DOWN DISCHARGE ELECTRIC HEATER PACKAGED UNIT WITH COOLING, MIXING BOX, LPD EVAPORATIVE COOLER INTAKE AND INTAKE HOOD

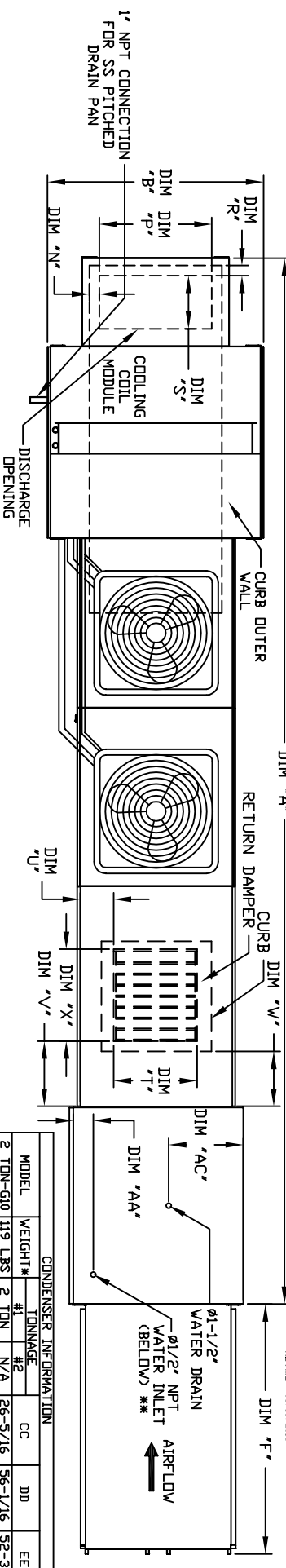

CONDENSER INFORMATION

MODEL	WEIGHT #	TONNAGE	CC	DD	EE
2 TON-G10	119 LBS	2 TON	N/A	26-5/16	56-1/16
3 TON-G10	134 LBS	3 TON	N/A	33-5/16	63-1/16
5 TON-G10	253 LBS	2 TON	3 TON	33-5/16	63-1/16
5 TON-G10	302 LBS	2.5 TON	2.5 TON	32-13/16	62-9/16
5 TON-G15	197 LBS	5 TON	N/A	32-13/16	62-9/16
7.5 TON-G15	348 LBS	2.5 TON	5 TON	32-13/16	62-9/16
8 TON-G15	331 LBS	3 TON	5 TON	33-5/16	71-1/16
10 TON-G15	394 LBS	3 TON	5 TON	32-13/16	62-9/16
10 TON-G18	894 LBS	3 TON	5 TON	32-13/16	70-1/8
10 TON-920	894 LBS	5 TON	5 TON	32-13/16	91-15/16

R410A REFRIGERANT

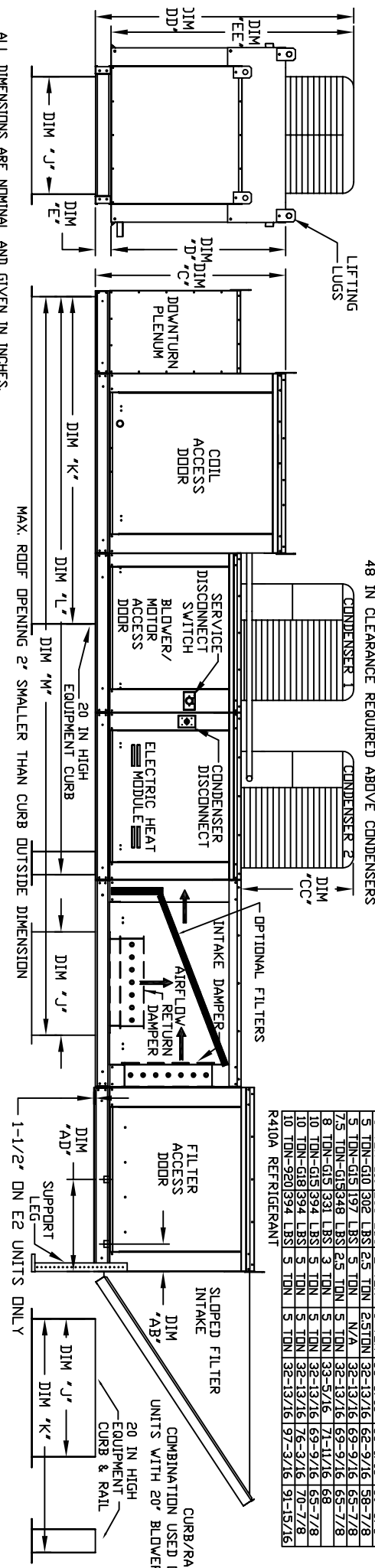

ALL DIMENSIONS ARE NOMINAL AND GIVEN IN INCHES.

MODEL	A	B	C	D	E	F	G	H	I	J	K	L	M	N	O	P	Q	R	S	T	U	V	W	X	Y	Z
E1-G10	209-1/2	39-3/8	42-3/4	39	3-3/4	153-5/8	21	71	131-5/8	163-1/16	3-9/16	13-7/8	11-1/2	14	8	11	12-1/2	18	4-1/2	6-1/4	18	19	16	20	19	16
E2-G15	229-1/2	49-3/8	47-3/4	44	3-3/4	151-5/8	31	79	145-5/8	182-1/16	4-5/16	22-3/8	11-9/16	18	11	14	17-1/2	24	4-1/2	5-3/4	20	19	16	20	19	16
E3-G18	231-5/8	54-3/8	56-3/8	51-1/8	5-1/4	176-3/8	35	84	150-5/8	190-1/16	5-5/16	22-3/8	11-1/2	18	11	14	17-1/2	24	4-1/2	5-3/4	20	19	16	20	19	16
E4-920	232-7/8	60-7/16	64-3/8	59-1/8	5-1/4	171-3/8	42	115-3/16	199-7/8	247-13/16	5-1/4	31-1/2	11-5/16	23-1/2	33	10	11	8	36	4-1/2	5-3/4	28-7/8	17-1/2	20	19	16

UNIT INFORMATION:

MODEL	TONNAGE RANGE	TOT. WEIGHT MAIN	MEDIA SIZE & QTY	VEL. @ MAX. CFM	MIN. MEDIA SIZE & QTY	VEL. @ MAX. CFM	MAX. FLOW RATE
E1-G10	2 Ton	1335 LBS	63"x32"x12"	648 FPM	20	6.5 GPH	20"x25"x2" (2), 16"x25"x2" (1)
E2-G15	5 Ton	1820 LBS	30"x36"x12"	867 FPM	28	8.4 GPH	15"x20"x2" (4), 15"x15"x2" (2)
E3-G18	10 Ton	2320 LBS	38"x43"x12"	705 FPM	35	10.15 GPH	18"x25"x2" (4), 16"x20"x2" (2)
E4-920	10 Ton	3480 LBS	45"x54"x12"	770 FPM	42	12.6 GPH	18"x25"x2" (4), 16"x20"x2" (2)

OPTIONAL MIXING BOX FILTERS

MODEL	TONNAGE RANGE	TOT. WEIGHT MAIN	MEDIA SIZE & QTY	VEL. @ MAX. CFM	MIN. MEDIA SIZE & QTY	VEL. @ MAX. CFM	MAX. FLOW RATE
E1-G10	2 Ton	1335 LBS	63"x32"x12"	648 FPM	20	6.5 GPH	20"x25"x2" (2), 16"x25"x2" (3)
E2-G15	5 Ton	1820 LBS	30"x36"x12"	867 FPM	28	8.4 GPH	15"x20"x2" (2), 15"x15"x2" (1)
E3-G18	10 Ton	2320 LBS	38"x43"x12"	705 FPM	35	10.15 GPH	18"x25"x2" (4), 15"x15"x2" (2)
E4-920	10 Ton	3480 LBS	45"x54"x12"	770 FPM	42	12.6 GPH	18"x25"x2" (4), 16"x20"x2" (2)

MAX. FILTER VELOCITY

MODEL	TONNAGE RANGE	TOT. WEIGHT MAIN	MEDIA SIZE & QTY	VEL. @ MAX. CFM	MIN. MEDIA SIZE & QTY	VEL. @ MAX. CFM	MAX. FLOW RATE
E1-G10	2 Ton	1335 LBS	63"x32"x12"	648 FPM	20	6.5 GPH	20"x25"x2" (2), 16"x25"x2" (3)
E2-G15	5 Ton	1820 LBS	30"x36"x12"	867 FPM	28	8.4 GPH	15"x20"x2" (4), 15"x15"x2" (2)
E3-G18	10 Ton	2320 LBS	38"x43"x12"	705 FPM	35	10.15 GPH	18"x25"x2" (4), 15"x15"x2" (2)
E4-920	10 Ton	3480 LBS	45"x54"x12"	770 FPM	42	12.6 GPH	18"x25"x2" (4), 16"x20"x2" (2)