

MODULAR OUTDOOR SIDE DISCHARGE ELECTRIC HEATER PACKAGED UNIT WITH COOLING, MIXING BOX, LPD EVAPORATIVE COOLER INTAKE AND INTAKE HOOD

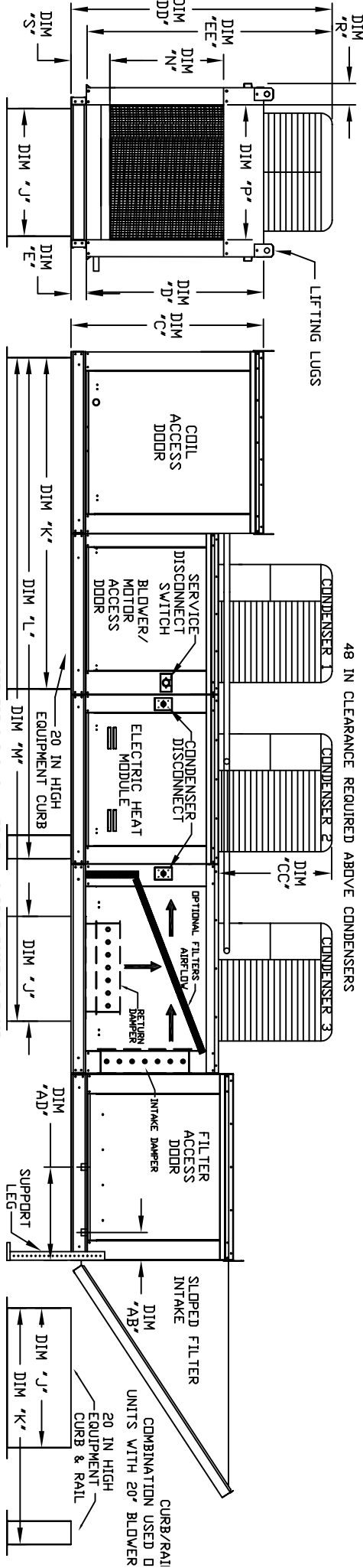
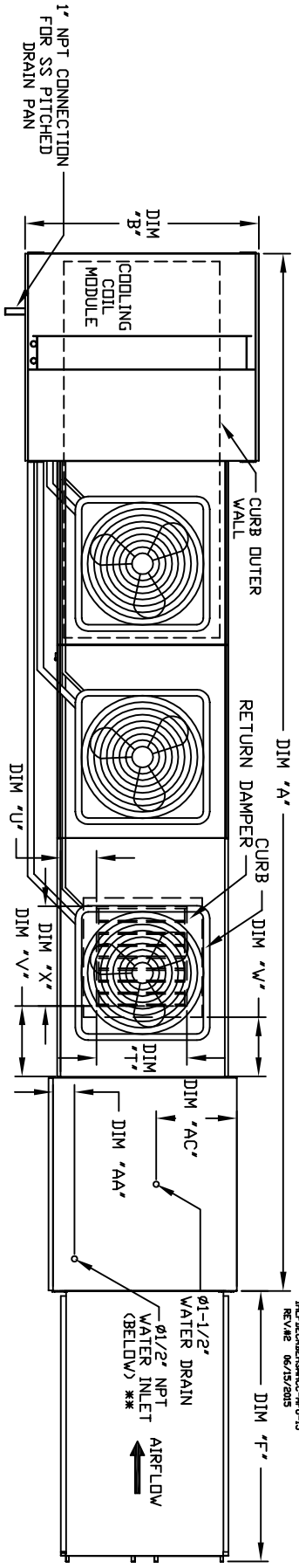

ALL DIMENSIONS ARE NOMINAL AND GIVEN IN INCHES.

MODEL	UNIT DIMENSIONS										CURB/RAIL										DISCHARGE OPENING										RETURN DAMPER OPENING										WATER INLET										DRAIN OPENING										INTAKE FILTER SIZE & QTY										MAX FILTER VELOCITY																																																																																																																																																																																																																																																																																																																																																																																																																																																																																																																																																																																																																																												
	A	B	C	D	E	F	J	K	L	M	N	P	R	S	T	U	V	W	X	AA	AB	AC	AD	AE	AF	AG	AH	AI	AJ	AK	AL	AM	AN	AO	AP	AQ	AR	AS	AT	AU	AV	AW	AX	AY	AZ	BA	BB	BC	BD	BE	BF	BG	BH	BI	BJ	BK	BL	BM	BN	BO	BP	BQ	BR	BS	BT	BU	BV	BW	BX	BY	BZ	CA	CB	CC	CD	CE	CF	CG	CH	CI	CJ	CK	CL	CM	CN	CO	CP	CQ	CR	CS	CT	CU	CV	CW	CX	CY	CZ	DA	DB	DC	DD	DE	DF	DG	DH	DI	DJ	DK	DL	DM	DN	DO	DP	DQ	DR	DS	DT	DU	DV	DW	DX	DY	DZ	EA	EB	EC	ED	EE	EF	EG	EH	EI	EJ	EK	EL	EM	EN	EO	EP	EQ	ER	ES	ET	EU	EV	EW	EX	EY	EZ	FA	FB	FC	FD	FE	FF	FG	FH	FI	FJ	FK	FL	FM	FN	FO	FP	FQ	FR	FS	FT	FU	FV	FW	FX	FY	FZ	GA	GB	GC	GD	GE	GF	GG	GH	GI	GJ	GK	GL	GM	GN	GO	GP	GQ	GR	GS	GT	GU	GV	GW	GX	GY	GZ	HA	HB	HC	HD	HE	HF	HG	HH	HI	HJ	HK	HL	HM	HN	HO	HP	HQ	HR	HS	HT	HU	HV	HW	HX	HY	HZ	IA	IB	IC	ID	IE	IF	IG	IH	II	IJ	IK	IL	IM	IN	IO	IP	IQ	IR	IS	IT	IU	IV	IW	IX	IY	IZ	JA	JB	JC	JD	JE	JF	JG	JH	JI	JJ	JK	JL	JM	JN	JO	JP	JQ	JR	JS	JT	JU	JV	JW	JX	JY	JZ	KA	KB	KC	KD	KE	KF	KG	KH	KI	KJ	KL	KM	KN	KO	KP	KQ	KR	KS	KT	KU	KV	KW	KX	KY	KZ	LA	LB	LC	LD	LE	LF	LG	LH	LI	LJ	LK	LL	LM	LN	LO	LP	LQ	LR	LS	LT	LU	LV	LW	LX	LY	LZ	MA	MB	MC	MD	ME	MF	MG	MH	MI	MJ	MK	ML	MM	MN	MO	MP	MQ	MR	MS	MT	MU	MV	MW	MX	MY	MZ	NA	NB	NC	ND	NE	NF	NG	NH	NI	NJ	NK	NL	NM	NO	NP	NQ	NR	NS	NT	NU	NV	NW	NX	NY	NZ	OA	OB	OC	OD	OE	OF	OG	OH	OI	OJ	OK	OL	OM	ON	OO	OP	OQ	OR	OS	OT	OU	OV	OW	OX	OY	OZ	PA	PB	PC	PD	PE	PF	PG	PH	PI	PJ	PK	PL	PM	PN	PO	PP	PQ	PR	PS	PT	PU	PV	PW	PX	PY	PZ	QA	QB	QC	QD	QE	QF	QG	QH	QI	QJ	QK	QL	QM	QN	QO	QP	QQ	QR	QS	QT	QU	QV	QW	QX	QY	QZ	RA	RB	RC	RD	RE	RF	RG	RH	RI	RJ	RK	RL	RM	RN	RO	RP	RQ	RR	RS	RT	RU	RV	RW	RX	RY	RZ	SA	SB	SC	SD	SE	SF	SG	SH	SI	SJ	SK	SL	SM	SN	SO	SP	SQ	SR	SS	ST	SU	SV	SW	SX	SY	SZ	TA	TB	TC	TD	TE	TF	TG	TH	TI	TJ	TK	TL	TM	TN	TO	TP	TQ	TR	TS	TT	TU	TV	TW	TX	TY	TZ	UA	UB	UC	UD	UE	UF	UG	UH	UI	UJ	UK	UL	UM	UN	UO	UP	UQ	UR	US	UT	UU	UV	UW	UX	UY	UZ	VA	VB	VC	VD	VE	VF	VG	VH	VI	VJ	VK	VL	VM	VN	VO	VP	VQ	VR	VS	VT	VU	VV	VW	VX	VY	VZ	WA	WB	WC	WD	WE	WF	WG	WH	WI	WJ	WK	WL	WM	WN	WO	WP	WQ	WR	WS	WT	WU	WV	WW	WX	WY	WZ	XA	XB	XC	XD	XE	XF	XG	XH	XI	XJ	XK	XL	XM	XN	XO	XP	XQ	XR	XS	XT	XU	XV	XW	XX	XY	XZ	YA	YB	YC	YD	YE	YF	YG	YH	YI	YJ	YK	YL	YM	YN	YO	YP	YQ	YR	YS	YT	YU	YV	YW	YX	YZ	ZA	ZB	ZC	ZD	ZE	ZF	ZG	ZH	ZI	ZJ	ZK	ZL	ZM	ZN	ZO	ZP	ZQ	ZR	ZS	ZT	ZU	ZV	ZW	ZX	ZY
E3-G18	207-1/4	54-3/8	56-3/8	51-1/8	5-1/4	76-3/8	35	84	126-1/4	165-11/16	29-5/8	30	11-1/2	7-3/8	28	8	7	4-1/2	30	4-1/2	5-3/4	23-1/2	17-1/2	16-5/8	20-5/8	13000	457 FPM																																																																																																																																																																																																																																																																																																																																																																																																																																																																																																																																																																																																																																																																																								
E4-920	262-1/2	60-7/16	64-3/8	59-1/8	5-1/4	71-3/8	42	115-3/16	169-1/2	217-7/16	36-3/4	34	12-1/2	7-3/8	33	10	11	8	36	4-1/2	5-3/4	28-7/8	17-1/2	20-5/8	13300	565 FPM																																																																																																																																																																																																																																																																																																																																																																																																																																																																																																																																																																																																																																																																																									

MODEL	TONNAGE RANGE			CELDEX EVAPORATIVE COOLING UNIT			OPTIONAL MIXING BOX FILTERS		
	MIN	MAX	TOT. WEIGHT	MEDIA SIZE & QTY	VEL. @ MAX. CFM	MAX. FLOW RATE	MODEL	FILTER SIZE & QTY	MAX. FLOW RATE
E3-G18	15 Ton	15 Ton	180 LBS	38"x43"x12"	705 FPM	35	G18	15"x20"x2" (4), 15"x15"x2" (2)	457 FPM
E4-920	15 Ton	15 Ton	3290 LBS	45"x54"x12"	770 FPM	42	920	18"x25"x2" (4), 16"x20"x2" (2)	565 FPM

MADD CONDENSING UNIT WEIGHT TO WEIGHT IN TABLE ABOVE ** MAX EVAP WATER PRESSURE = 50 PSI @ 70 DEG F

CONDENSER INFORMATION								
MODEL	WEIGHT*	#1	#2	#3	CC	DD	EE	
15 TON-G18/920	LBS	5	TON	5	TON	32-13/16	76-3/16	70-7/8
15 TON-G18/920	LBS	5	TON	5	TON	32-13/16	97-3/16	91-15/16

* WEIGHT DOES NOT INCLUDE CURB/RAIL WEIGHT. ** WEIGHT DOES NOT INCLUDE CURB/RAIL WEIGHT. *** WEIGHT DOES NOT INCLUDE CURB/RAIL WEIGHT.