

MODULAR OUTDOOR IBT HEATER WITH MIXING BOX, COOLING COIL AND INTAKE HOOD

IMHCCSMBIBT-HRU-15
REV. #6 06/15/2015

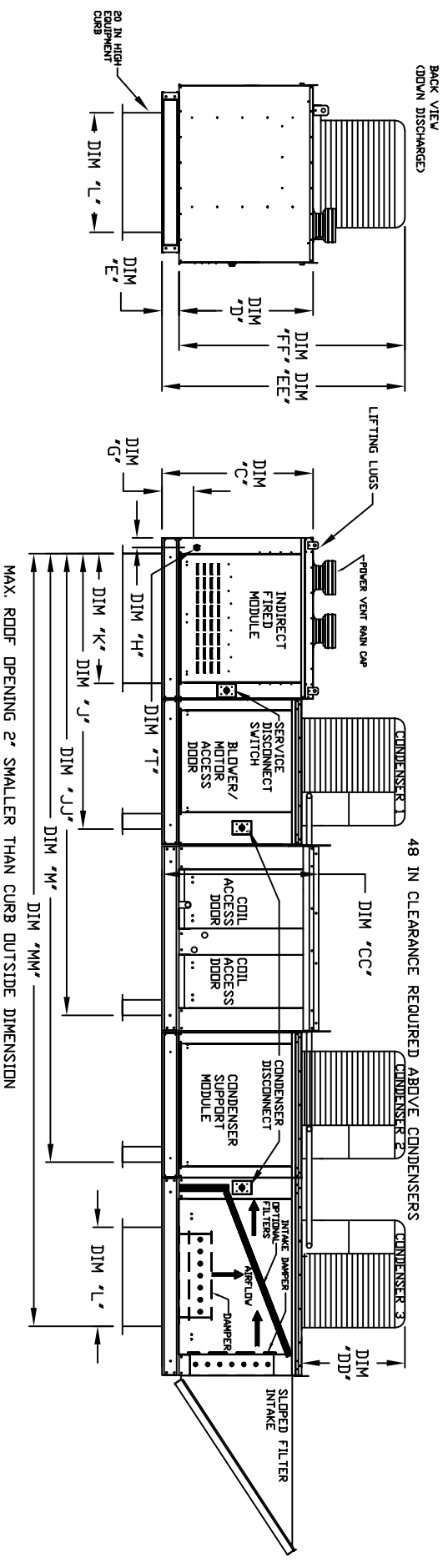
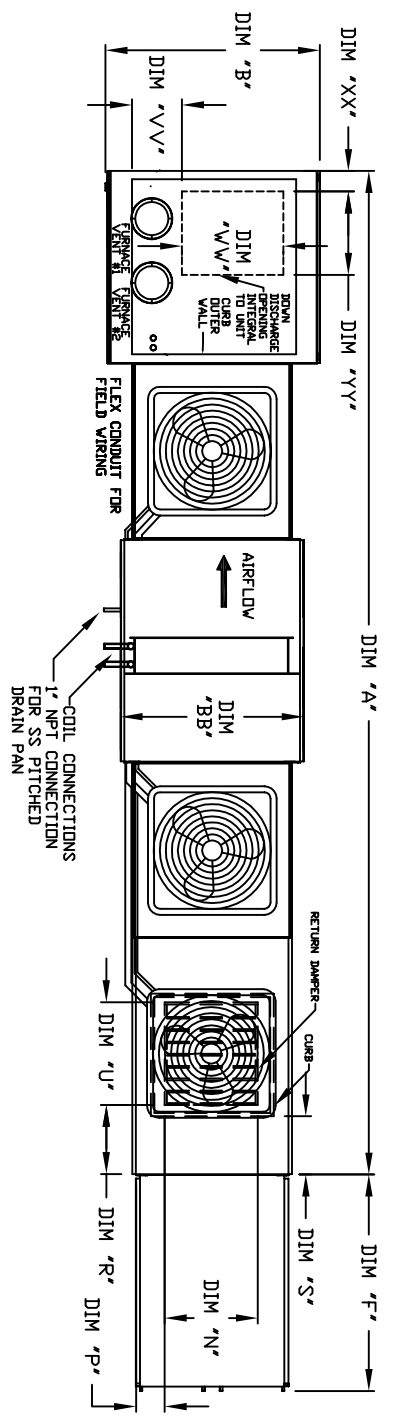
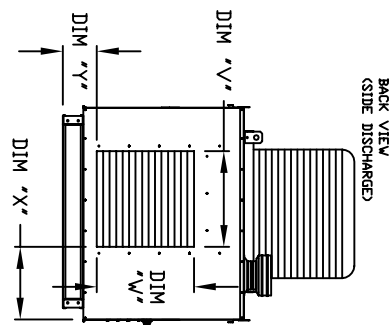

ALL DIMENSIONS ARE NOMINAL AND GIVEN IN INCHES.

MODEL	WEIGHT (LBS.)	UNIT DIMENSIONS												MIXING BOX OPENING												SIDE DISCHARGE OPENING												DOWN DISCHARGE OPENING												GAS CONNECTION	FURNACES
		A	B	BB	C	D	E	F	G	H	J	K	L	M	NN	N	P	R	S	U	V	W	X	Y	VV	WW	XX	YY	ZZ																						
3-1BT-400-G18	2337	57-3/4	54-3/8	57-1/16	56-3/8	51-13/16	51-1/4	51-5/8	80-3/4	2-11/16	102-3/16	84	35	144-7/16	186-11/8	225-13/16	28	8	7	4-1/2	30	27-1/2	31	18-1/2	8-3/4	6-3/4	26-1/2	4-1/8	26-1/2	1																					
3-1BT-600-300-G18	2455	57-3/4	54-3/8	57-1/16	56-3/8	51-13/16	51-1/4	51-5/8	80-3/4	2-11/16	102-3/16	84	35	144-7/16	186-11/8	225-13/16	28	8	7	4-1/2	30	27-1/2	31	18-1/2	8-3/4	6-3/4	26-1/2	4-1/8	26-1/2	1																					
3-1BT-800-400-G18	2593	57-3/4	54-3/8	57-1/16	56-3/8	51-13/16	51-1/4	51-5/8	80-3/4	2-11/16	102-3/16	84	35	144-7/16	186-11/8	225-13/16	28	8	7	4-1/2	30	27-1/2	31	18-1/2	8-3/4	6-3/4	26-1/2	4-1/8	26-1/2	1																					
4-1BT-400-920	3162	897-1/4	57-3/4	60-7/16	57-1/16	54-3/8	51-13/16	51-1/4	76-3/8	80-3/4	2-11/16	121-1/4	42	42	175-9/16	229-7/8	277-9/16	33	10	11	8	36	28-1/2	34	18-1/2	8-3/4	6-1/2	26-1/2	4-1/8	26-1/2	1																				
4-1BT-800-400-920	3379	897-1/4	57-3/4	60-7/16	57-1/16	54-3/8	51-13/16	51-1/4	76-3/8	80-3/4	2-11/16	121-1/4	42	42	175-9/16	229-7/8	277-9/16	33	10	11	8	36	28-1/2	34	18-1/2	8-3/4	6-1/2	26-1/2	4-1/8	26-1/2	1																				

MODEL	WEIGHT #1	#2	#3	CC	DD	EE	TUNNAGE			COMBUSTION			GAS PRESSURE		
							BTU	TON	5 TON	BTU	TON	5 TON	MIN	MAX	MAX
3-1BT-400-G18	400	333	320				6	800Z	7" VC	14" VC	14" VC	7" VC	14" VC	14" VC	
3-1BT-600-300-G18	600	40	480				12	800Z	7" VC	14" VC	14" VC	7" VC	14" VC	14" VC	
3-1BT-800-400-G18	800	800	640				12	800Z	7" VC	14" VC	14" VC	7" VC	14" VC	14" VC	
4-1BT-400-920	400	593	320				6	800Z	7" VC	14" VC	14" VC	7" VC	14" VC	14" VC	
4-1BT-800-400-920	800	593	640				12	800Z	7" VC	14" VC	14" VC	7" VC	14" VC	14" VC	

OPTIONAL MIXING BOX FILTERS
G18 15"x20"x2" (A) 15"x15"x2" (B)
G20 18"x25"x2" (A) 14"x20"x2" (B)