

MODULAR OUTDOOR SIDE DISCHARGE ELECTRIC HEATER PACKAGED UNIT WITH COOLING, V-BANK AND INTAKE HOOD

1" NPT CONNECTION FOR SS PITCHED DRAIN PAN

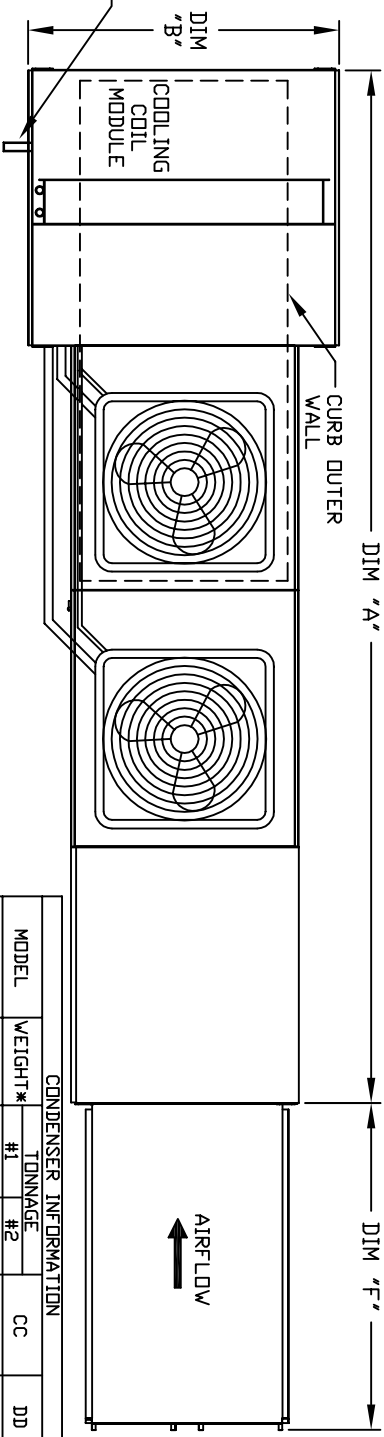

48 IN CLEARANCE REQUIRED ABOVE CONDENSERS

CONDENSER INFORMATION

MODEL	WEIGHT*	TONNAGE #1	TONNAGE #2	CC	DD	EE
2 TON-G10	119 LBS	2 TON	N/A	26-5/16	56-1/16	52-3/8
3 TON-G10	134 LBS	3 TON	N/A	33-5/16	63-1/16	59-3/8
5 TON-G10	253 LBS	2 TON	3 TON	33-5/16	63-1/16	59-3/8
5 TON-G10	302 LBS	2 1/2 TON	2 1/2 TON	32-13/16	62-9/16	58-7/8
5 TON-G15	197 LBS	5 TON	N/A	32-13/16	69-9/16	65-7/8
7 1/2 TON-G15	348 LBS	2 1/2 TON	5 TON	32-13/16	69-9/16	65-7/8
8 TON-G15	331 LBS	3 TON	5 TON	33-5/16	71-11/16	68
10 TON-G18	394 LBS	3 TON	5 TON	32-13/16	69-9/16	65-7/8
10 TON-G18	394 LBS	5 TON	5 TON	32-13/16	76-3/16	70-7/8
10 TON-G20	394 LBS	5 TON	5 TON	32-13/16	97-3/16	91-15/16

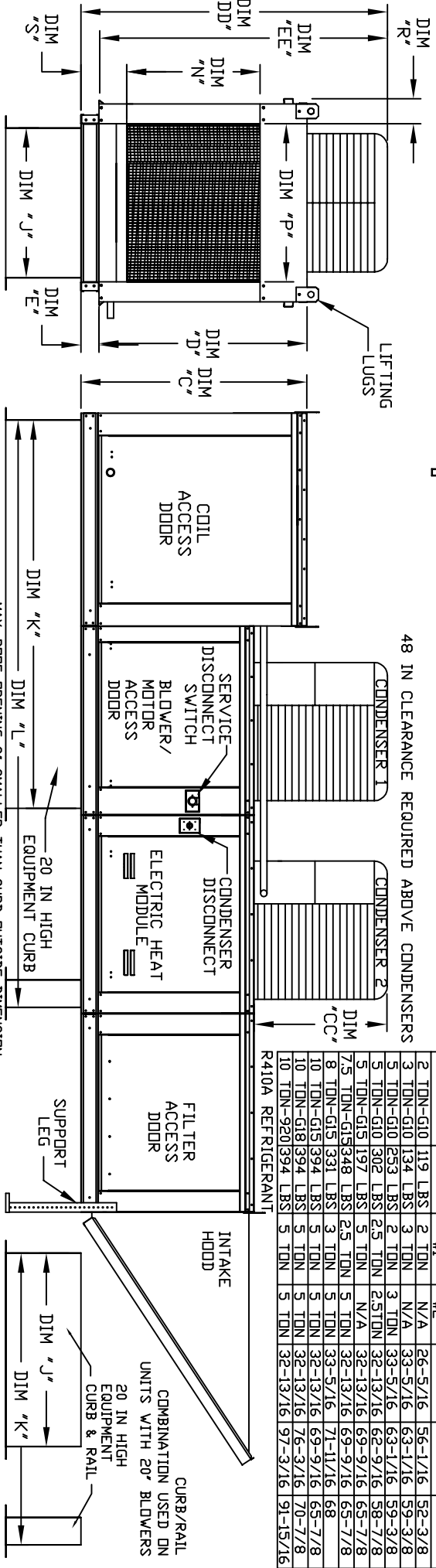

ALL DIMENSIONS ARE NOMINAL AND GIVEN IN INCHES.

MAX. ROOF OPENING 2" SMALLER THAN CURB OUTSIDE DIMENSION

MODEL	WEIGHT	UNIT DIMENSIONS												
		A	B	C	D	E	F	J	K	L	N	P	R	S
E1-G10	1000 LBS	148-7/8	39-3/8	42-3/4	39	3-3/4	44-3/8	21	71	113-1/4	17-1/2	16	11	5-3/4
E2-G15	1370 LBS	156-7/8	49-3/8	47-3/4	44	3-3/4	53-5/8	31	79	121-1/4	29-3/4	22-3/4	12-5/8	5-3/8
E3-G18	1645 LBS	167-7/8	54-3/8	56-3/8	51-1/8	5-1/4	51-5/8	35	84	126-1/4	29-5/8	30	11-1/2	7-3/8
E4-920	2670 LBS	208-3/16	60-7/16	64-3/8	59-1/8	5-1/4	76-3/8	42	115-3/16	169-1/2	36-3/4	34	12-1/2	7-3/8

UNIT INFORMATION

MODEL	TONNAGE RANGE		FILTER SIZE & QTY		MAX. FILTER VELOCITY
	MIN	MAX			
E1-G10	2 Ton	5 Ton	20"x25"x2" (3)	@3600 CFM = 418 FPM	
E2-G15	5 Ton	10 Ton	16"x20"x2" (8)	@6500 CFM = 464 FPM	
E3-G18	10 Ton	10 Ton	20"x25"x2" (8)	@8000 CFM = 348 FPM	
E4-920	10 Ton	10 Ton	16"x20"x2" (15)	@13000 CFM = 495 FPM	

*WARRANTY INFORMATION VISIT WWW.TRANE.COM FOR MORE INFORMATION