

OUTDOOR SIDE DISCHARGE MOD PACKAGE UNIT, LPD EVAPORATIVE COOLER INTAKE, INTAKE HOOD AND OPTIONAL MIXING BOX

HPD/CHOC/SAM/HW
REV.02 06/15/2015



CONDENSER INFORMATION

MODEL	WEIGHT*	#1 TONNAGE	#2 TONNAGE	CC	DD	EE
2 TON-G10	119 LBS	2 TON	N/A	26-5/16	56-1/16	52-3/8
3 TON-G10	134 LBS	3 TON	N/A	33-5/16	63-1/16	59-3/8
5 TON-G10	253 LBS	2 TON	3 TON	33-5/16	63-1/16	59-3/8
5 TON-G10	302 LBS	2.5 TON	2.5 TON	32-13/16	62-9/16	58-7/8
5 TON-G12	197 LBS	5 TON	N/A	32-13/16	69-9/16	65-7/8
7.5 TON-G12	488 LBS	2.5 TON	5 TON	32-13/16	69-9/16	65-7/8
10 TON-G12	394 LBS	5 TON	5 TON	32-13/16	69-9/16	65-7/8
7.5 TON-G15	197 LBS	5 TON	N/A	32-13/16	69-9/16	65-7/8
8 TON-G15	302 LBS	2.5 TON	5 TON	32-13/16	69-9/16	65-7/8
10 TON-G15	331 LBS	3 TON	5 TON	33-5/16	71-11/16	68
10 TON-G15	394 LBS	5 TON	5 TON	32-13/16	69-9/16	65-7/8
10 TON-G18	394 LBS	5 TON	5 TON	32-13/16	76-3/16	70-7/8
10 TON-G20	394 LBS	5 TON	5 TON	32-13/16	97-3/16	91-15/16

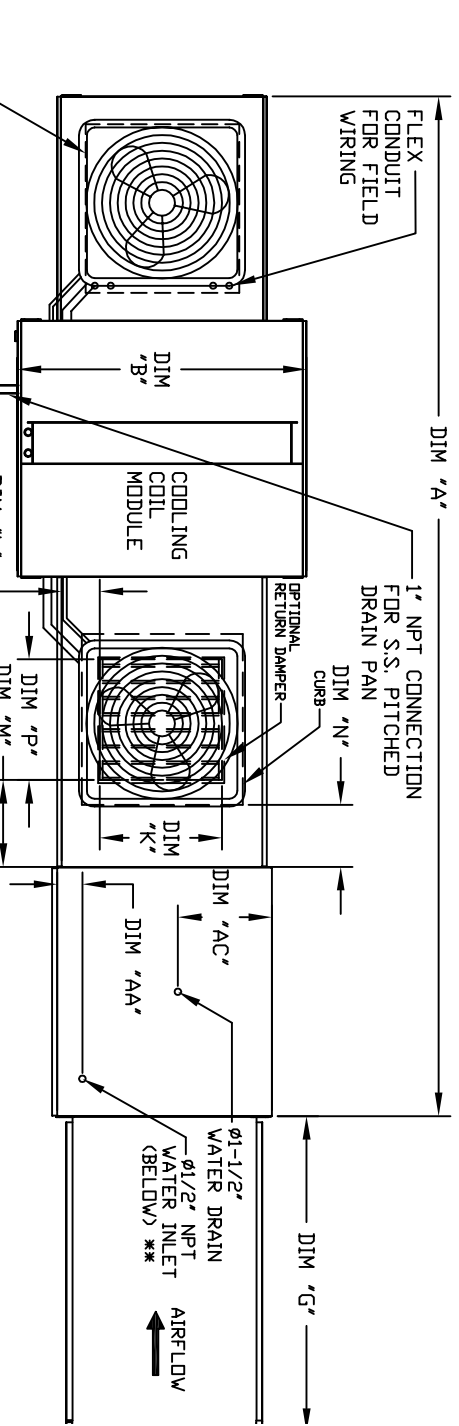

OPTIONAL MIXING BOX FILTERS

MODEL	FILTER SIZE & QTY
G10	10"x16"x2" (5)
G12	20"x25"x2" (2), 16"x25"x2" (1)
G15	20"x25"x2" (2), 16"x25"x2" (1)
G18	15"x20"x2" (4), 15"x15"x2" (2)
920	18"x25"x2" (4), 16"x20"x2" (2)

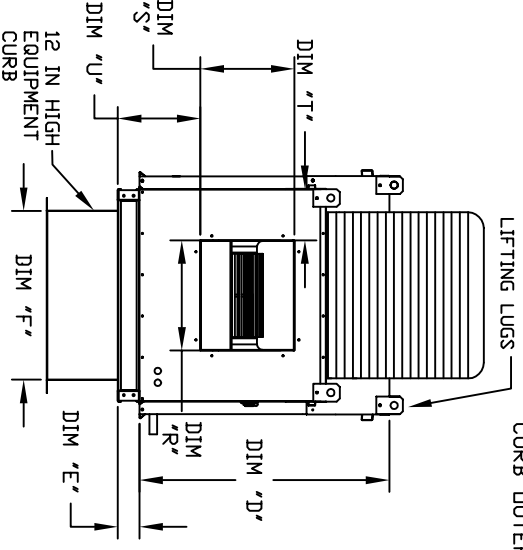

ALL DIMENSIONS ARE NOMINAL AND GIVEN IN INCHES.

MAX. ROOF OPENING 2' SMALLER THAN CURB OUTSIDE DIMENSION.

DISCHARGE OPENING

TONNAGE RANGE

MODEL	A	B	C	D	E	F	G	H	I	J	K	L	M	N	P	R	S	T	U	MIN	MAX	AA	AB	AC	AD
G10	148-7/8	39-3/8	42-3/4	39	3-3/4	21	53-5/8	98-5/8	65-13/16	14	8	14	12-1/2	18	13-1/4	11-1/2	5-3/8	11-7/8	2	5	4-1/2	6-1/4	18	16	
G12	162-7/8	49-3/8	47-3/4	44	3-3/4	31	51-5/8	112-5/8	74-5/8	22-3/4	8	11	7-1/2	24	15-3/4	13-9/16	10-1/8	13-1/16	5	10	4-1/2	5-3/4	20	19	
G15	162-7/8	49-3/8	47-3/4	44	3-3/4	31	51-5/8	112-5/8	74-5/8	22-3/4	8	11	7-1/2	24	15-3/4	13-9/16	10-1/8	13-1/16	5	10	4-1/2	5-3/4	20	19	
G18	165	54-3/8	56-3/8	51-1/8	5-1/4	35	76-3/8	120-1/8	79-3/16	28	8	7	4-1/2	30	22	19	9	17-7/8	10	10	4-1/2	5-3/4	23-1/2	17-1/2	
920	208-3/16	60-7/16	64-3/8	59-1/8	5-1/4	42	71-3/8	153-15/16	104-9/32	33	10	11	8	36	24-7/8	24-7/8	11-1/16	19-1/8	10	10	4-1/2	5-3/4	28-7/8	17-1/2	

UNIT INFORMATION

LPD CELDEK EVAPORATIVE COOLING UNIT

MODEL	FILTER SIZE & QTY	TOT. WEIGHT	MEDIA SIZE & QTY	NOZZLES	MAX. FLOW RATE
G10	20"x25"x2" (3)	955 LBS	25"x32"x12"	20	6.5 GPH
G12	16"x20"x2" (6)	1315 LBS	30"x36"x12"	28	8.4 GPH
G15	16"x20"x2" (6)	1325 LBS	30"x36"x12"	28	8.4 GPH
G18	16"x20"x2" (10)	1730 LBS	38"x43"x12"	35	10.15 GPH
920	20"x25"x2" (8)	2580 LBS	45"x54"x12"	42	12.6 GPH

*ADD CONDENSING UNIT WEIGHT TO WEIGHT IN TABLES ABOVE

MAX. ROOF OPENING 2' SMALLER THAN CURB OUTSIDE DIMENSION