

OUTDOOR DOWN DISCHARGE MOD PACKAGE UNIT, V-BANK, LPD EVAPORATIVE COOLER INTAKE, SCREEN INTAKE AND OPTIONAL MIXING BOX

SVB:09C93C04H-HU  
REV:02 06/15/2010



CONDENSER INFORMATION

MODEL	WEIGHT#	#1	#2	CC	DD	EE
2 TON-G10 119 LBS	2 TON	N/A	26-5/16	56-1/16	52-3/8	
3 TON-G10 134 LBS	3 TON	N/A	33-5/16	63-1/16	59-3/8	
3 TON-G10 253 LBS	2 TON	3 TON	33-5/16	63-1/16	59-3/8	
5 TON-G10 302 LBS	2.5 TON	2.5 TON	32-13/16	62-9/16	58-7/8	
5 TON-G12 197 LBS	5 TON	N/A	32-13/16	62-9/16	58-7/8	
7.5 TON-G12 348 LBS	2.5 TON	5 TON	32-13/16	62-9/16	58-7/8	
10 TON-G12 394 LBS	5 TON	5 TON	32-13/16	62-9/16	58-7/8	
5 TON-G15 197 LBS	5 TON	N/A	32-13/16	62-9/16	58-7/8	
7.5 TON-G15 302 LBS	2.5 TON	5 TON	32-13/16	62-9/16	58-7/8	
8 TON-G15 331 LBS	3 TON	5 TON	33-5/16	71-1/16	68	
10 TON-G15 394 LBS	5 TON	5 TON	32-13/16	62-9/16	58-7/8	
10 TON-G18 394 LBS	5 TON	5 TON	32-13/16	76-3/16	70-7/8	
10 TON-G20 394 LBS	5 TON	5 TON	32-13/16	97-3/16	91-15/16	

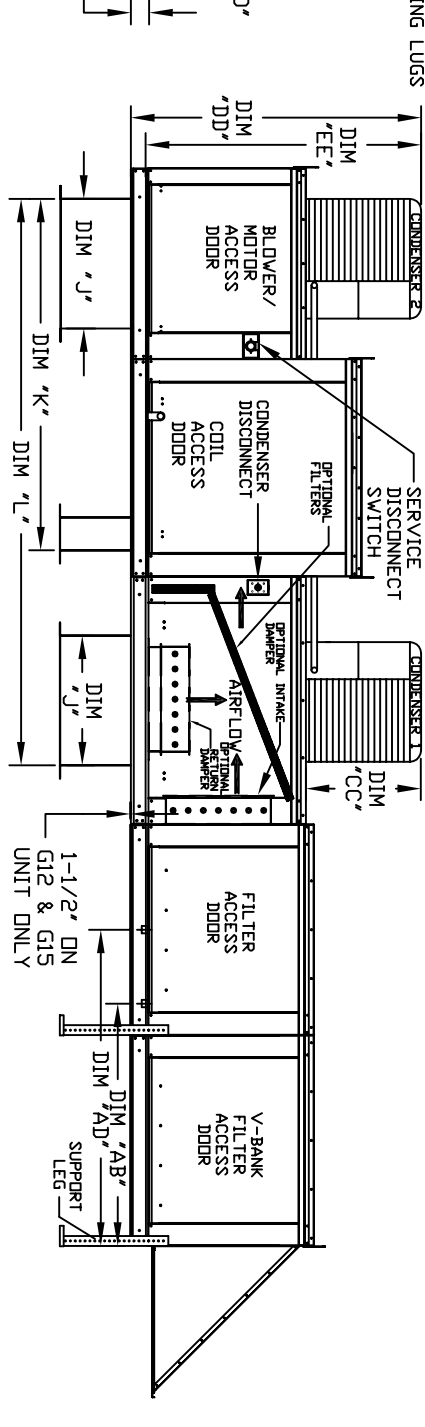
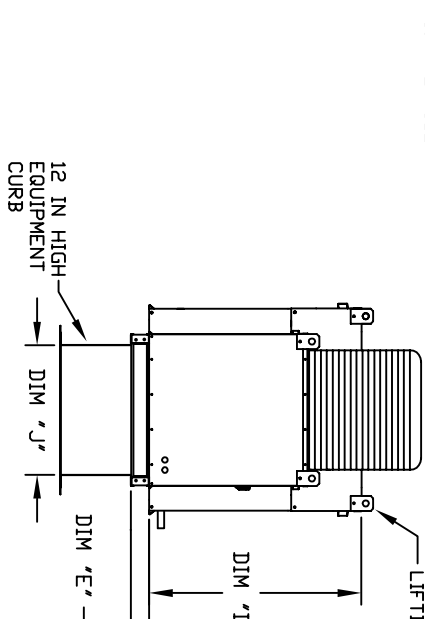
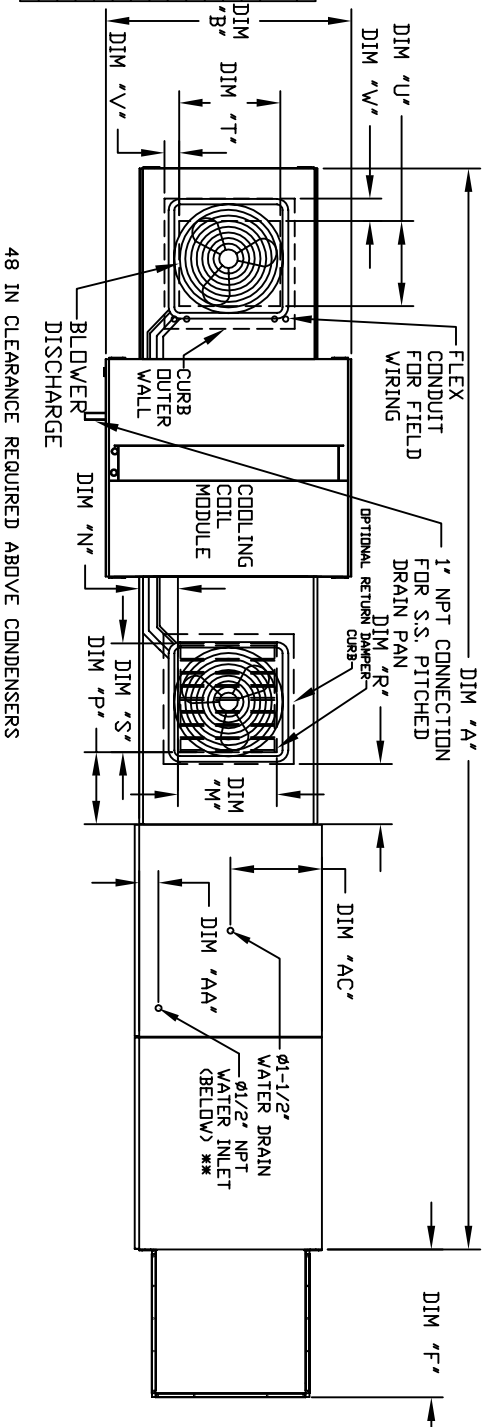

ALL DIMENSIONS ARE NOMINAL AND GIVEN IN INCHES.

MODEL	A	B	C	D	E	F	J	K	L	M	N	P	R	S	T	U	V	W	MIN	MAX	AA	AB	AC	AD
G10	181-1/8	39-3/8	42-3/4	39	3-3/4	30-5/16	21	65-13/16	98-5/8	14	8	14	12-1/2	18	13-1/4	11-1/2	3-7/8	1-3/4	2 Ton	5 Ton	4-1/2	38-1/2	18	48-1/4
G12	201-1/8	49-3/8	47-3/4	44	3-3/4	34-3/16	31	74-5/8	112-5/8	22-3/4	8	11	7-1/2	24	15-3/4	13-9/16	7-5/8	7-15/16	5 Ton	10 Ton	4-1/2	44	20	57-1/4
G15	201-1/8	49-3/8	47-3/4	44	3-3/4	34-3/16	31	74-5/8	112-5/8	22-3/4	8	11	7-1/2	24	18-3/4	16	6-1/8	5-1/2	5 Ton	10 Ton	4-1/2	44	20	57-1/4
G18	200-3/8	54-3/8	56-3/8	51-1/8	5-1/4	47-1/4	35	79-3/16	120-1/8	28	8	7	4-1/2	30	22	19	6-1/2	7	5 Ton	10 Ton	4-1/2	44	20	57-1/4
G20	243-9/16	60-7/16	64-3/8	59-1/8	5-1/4	49-5/8	42	104-9/32	153-15/16	33	10	11	8	36	24-7/8	24-7/8	8-9/16	1-1/8	10 Ton	10 Ton	4-1/2	44	20	57-1/4

V-BANK FILTER

MODEL	LPD CELDEK EVAPORATIVE COOLING UNIT	OPTIONAL MIXING BOX FILTERS
G10	16"x20"x2" (8)	10"x16"x2" (5)
G12	20"x25"x2" (8)	20"x25"x2" (2), 16"x25"x2" (1)
G15	20"x25"x2" (8)	20"x25"x2" (2), 16"x25"x2" (1)
G18	16"x20"x2" (15)	15"x20"x2" (4), 15"x15"x2" (2)
G20	20"x25"x2" (12)	18"x25"x2" (4), 16"x20"x2" (2)

V-BANK FILTER SIZE & QTY

MODEL	LPD CELDEK EVAPORATIVE COOLING UNIT	OPTIONAL MIXING BOX FILTERS
G10	1060 LBS	10"x16"x2" (5)
G12	1440 LBS	20"x25"x2" (2), 16"x25"x2" (1)
G15	1450 LBS	20"x25"x2" (2), 16"x25"x2" (1)
G18	1855 LBS	15"x20"x2" (4), 15"x15"x2" (2)
G20	2785 LBS	18"x25"x2" (4), 16"x20"x2" (2)

TOT. WEIGHT/MEDIA SIZE & QTY INDIZES/MAX. FLOW RATE

MODEL	TOT. WEIGHT	INDIZES	MAX. FLOW RATE
G10	1060 LBS	25"x32"x12"	20 GPH
G12	1440 LBS	30"x36"x12"	28 GPH
G15	1450 LBS	30"x36"x12"	28 GPH
G18	1855 LBS	38"x43"x12"	35 GPH
G20	2785 LBS	45"x54"x12"	42 GPH

ADD CONDENSING UNIT WEIGHT TO WEIGHT IN TABLES ABOVE