

OUTDOOR SIDE DISCHARGE MOD PACKAGE UNIT, V-BANK, LPD EVAPORATIVE COOLER INTAKE, SCREEN INTAKE AND OPTIONAL MIXING BOX

SVLP03PBCBC3SH4-HBU
REV#02 06/15/2015

CONDENSER INFORMATION					
MODEL	WEIGHT#	TONNAGE	CC	DD	EE
2 TON-G10	119 LBS	2 TON	N/A	26-5/16	56-1/16
3 TON-G10	134 LBS	3 TON	N/A	33-5/16	63-1/16
3 TON-G10	253 LBS	2 TON	N/A	33-5/16	63-1/16
5 TON-G10	302 LBS	2.5 TON	N/A	32-13/16	62-9/16
5 TON-G12	197 LBS	5 TON	N/A	32-13/16	62-9/16
7.5 TON-G12	348 LBS	2.5 TON	N/A	32-13/16	62-9/16
10 TON-G12	394 LBS	5 TON	N/A	32-13/16	62-9/16
10 TON-G12	394 LBS	5 TON	N/A	32-13/16	62-9/16
7.5 TON-G13	197 LBS	5 TON	N/A	32-13/16	62-9/16
7.5 TON-G13	302 LBS	2.5 TON	N/A	32-13/16	62-9/16
8 TON-G13	331 LBS	3 TON	N/A	33-5/16	71-11/16
10 TON-G13	394 LBS	5 TON	N/A	32-13/16	62-9/16
10 TON-G18	394 LBS	5 TON	N/A	32-13/16	62-9/16
10 TON-G18	394 LBS	5 TON	N/A	32-13/16	62-9/16
10 TON-G20	394 LBS	5 TON	N/A	32-13/16	62-9/16
410A REFRIGERANT					

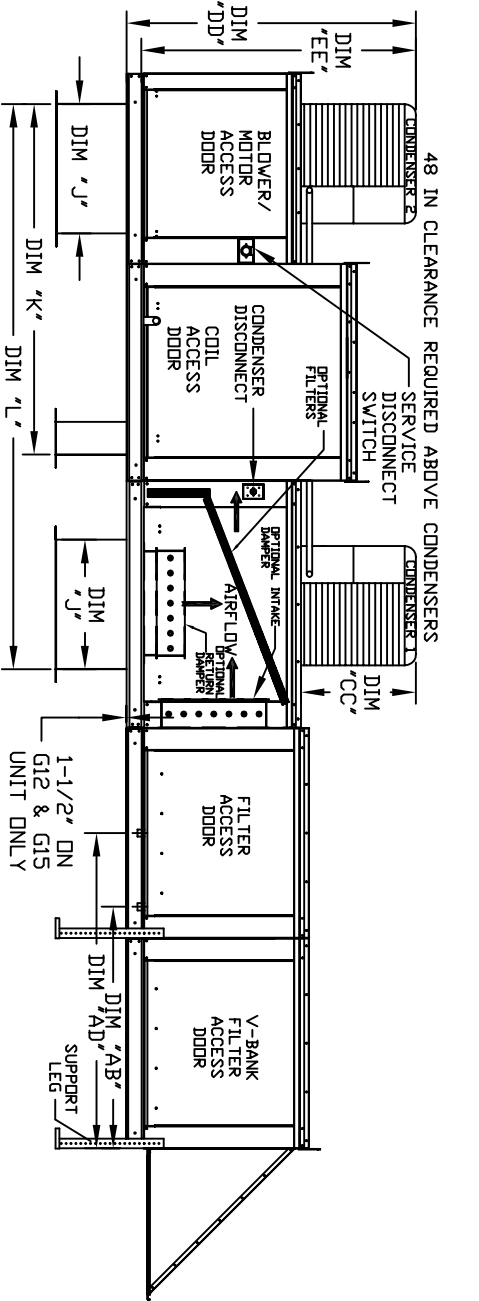
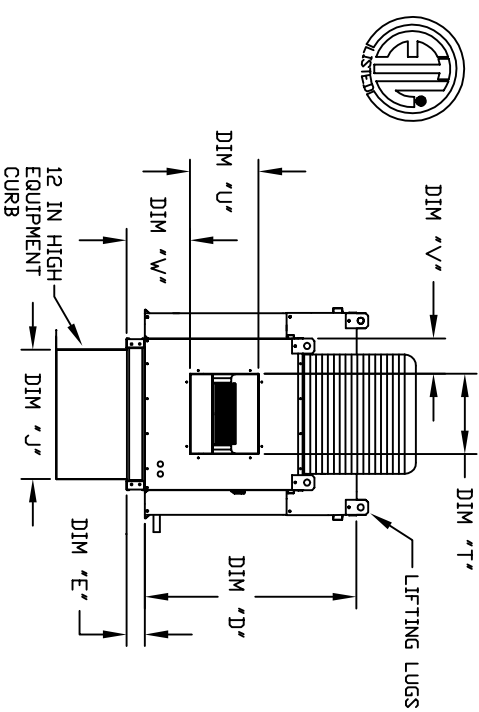
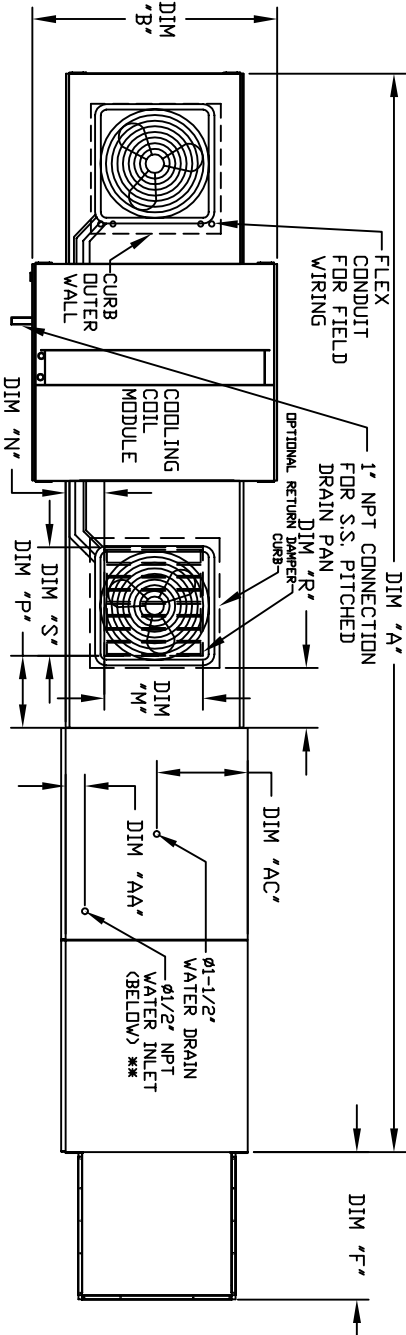

ALL DIMENSIONS ARE NOMINAL AND GIVEN IN INCHES.

MODEL	UNIT DIMENSIONS											DISCHARGE OPENING											TONNAGE RANGE					WATER INLET DRAIN OPENING				
	A	B	C	D	E	F	J	K	L	M	N	P	R	S	T	U	V	V	MIN	MAX	AA	AB	AC	AD								
G10	181-1/8	39-3/8	42-3/4	39	3-3/4	30-5/16	21	65-13/16	98-5/8	14	8	14	12-1/2	18	13-1/4	11-1/2	6-3/8	11-7/8	2 Ton	5 Ton	4-1/2	38-1/2	18	48-1/4								
G12	201-1/8	49-3/8	47-3/4	44	3-3/4	34-3/16	31	74-5/8	112-5/8	8	11	11	7-1/2	24	15-3/4	10-1/8	8-5/8	13-1/16	10 Ton	10 Ton	4-1/2	44	20	57-1/4								
G15	201-1/8	49-3/8	47-3/4	44	3-3/4	34-3/16	31	74-5/8	112-5/8	8	11	11	7-1/2	24	15-3/4	10-1/8	8-5/8	14-1/16	5 Ton	10 Ton	4-1/2	44	20	57-1/4								
G18	200-3/8	54-3/8	56-3/8	51-1/8	5-1/4	47-1/4	35	79-3/16	120-1/8	8	7	7	4-1/2	30	22	9	9	17-7/8	10 Ton	10 Ton	4-1/2	44	20	57-1/4								
920	R43-9/16	60-7/16	64-3/8	59-1/8	5-1/4	49-5/8	42	104-9/32	153-15/16	33	10	11	8	36	24-7/8	24-7/8	11-1/16	19-1/8	10 Ton	10 Ton	4-1/2	41-1/8	28-7/8	52-7/8								

V-BANK FILTER

MODEL	FILTER SIZE & QTY	LPD CELDEK EVAPORATIVE COOLING UNIT TOTL. WEIGHT MEDIA SIZE & QTY	NOZZLES	MAX. FLOW RATE
G10	16"x20"x2" (8)	1060 LBS	25"x32"x12"	20 GPH
G12	20"x25"x2" (8)	1440 LBS	30"x36"x12"	28 GPH
G15	20"x25"x2" (8)	1450 LBS	30"x36"x12"	28 GPH
G18	16"x20"x2" (15)	1855 LBS	38"x43"x12"	35 GPH
920	20"x25"x2" (12)	2785 LBS	45"x54"x12"	42 GPH

OPTIONAL MIXING BOX FILTERS

MODEL	FILTER SIZE & QTY
G10	10"x16"x2" (5)
G12	20"x25"x2" (2), 16"x25"x2" (1)
G15	20"x25"x2" (2), 16"x25"x2" (1)
G18	15"x20"x2" (4), 15"x15"x2" (2)
920	18"x25"x2" (4), 16"x20"x2" (2)

MAX. ROOF OPENING 2" SMALLER THAN CURB OUTSIDE DIMENSION

MAX. ROOF OPENING 2" SMALLER THAN CURB OUTSIDE DIMENSION

MAX. ROOF OPENING 2" SMALLER THAN CURB OUTSIDE DIMENSION

MAX. ROOF OPENING 2" SMALLER THAN CURB OUTSIDE DIMENSION

MAX. ROOF OPENING 2" SMALLER THAN CURB OUTSIDE DIMENSION

MAX. ROOF OPENING 2" SMALLER THAN CURB OUTSIDE DIMENSION

MAX. ROOF OPENING 2" SMALLER THAN CURB OUTSIDE DIMENSION