

MODULAR OUTDOOR SIDE DISCHARGE ELECTRIC HEATER PACKAGED UNIT WITH COOLING, LPD EVAPORATIVE COOLER INTAKE, V-BANK, MIXING BOX AND SCREEN INTAKE

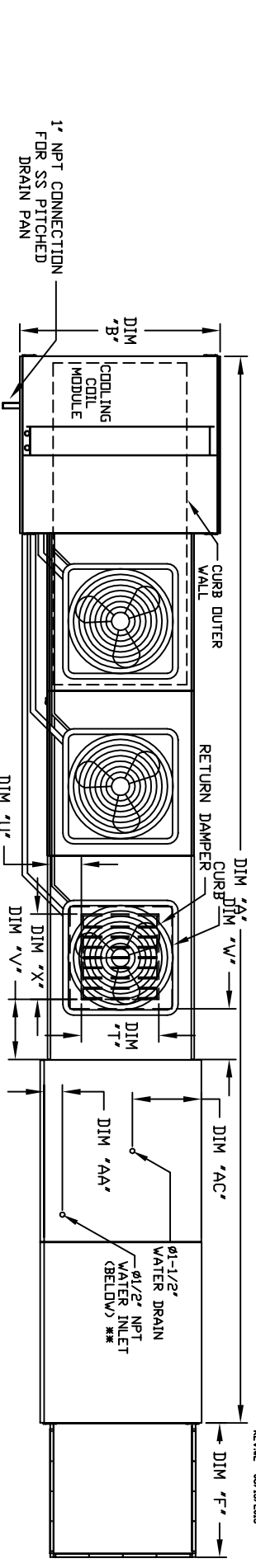

SY/BU/PC/CONDENSARC-49U-15  
REV#2 06/15/2015

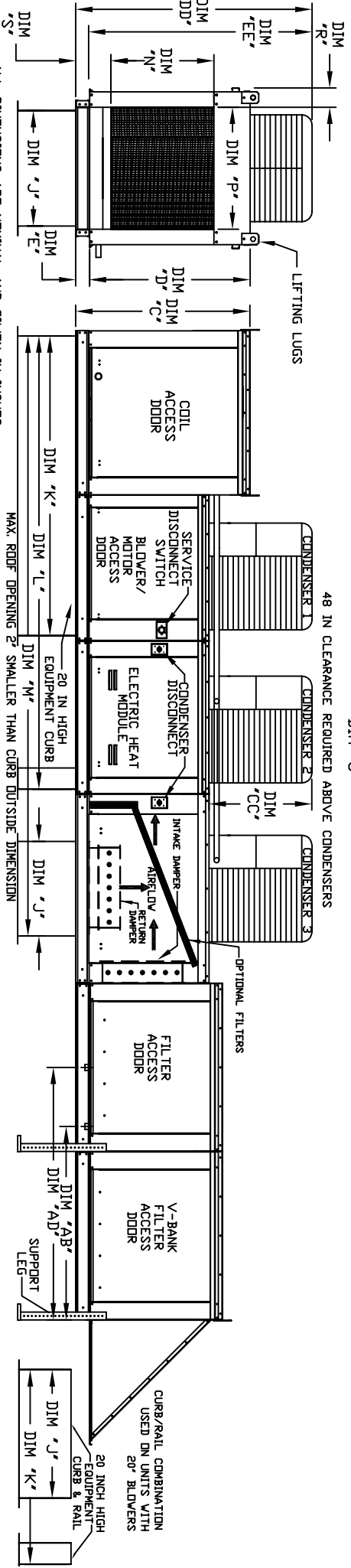

ALL DIMENSIONS ARE NOMINAL AND GIVEN IN INCHES.

MODEL	A	B	C	D	E	F	J	K	L	M	N	P	R	S	T	U	V	W	X	AA	AB	AC	AD	AE																				
E3-G18	242	5-7/8	154	3-7/8	56	3-7/8	51	1-7/8	5	1-7/4	47	1-7/4	35	84	126	1-1/4	203	15	1/6	29	5-7/8	30	11	1-1/2	7	3-7/8	28	8	7	4	1-1/2	30	4	1-1/2	41	1-7/8	23	1-1/2	52	7-7/8	16	20	2	15
E4-920	297	7-7/8	160	7-7/16	64	3-7/8	59	1-7/8	5	1-7/4	49	5-7/8	42	115	3-7/16	169	1-7/2	252	13	7/16	36	3-7/4	34	12	1-7/2	7	3-7/8	33	10	11	8	36	4	1-7/2	41	1-7/8	28	7-7/8	18	20	2	15		

MAX. ROOF OPENING 2" SMALLER THAN CURB OUTSIDE DIMENSION

20 INCH HIGH EQUIPMENT CURB

OPTIONAL MIXING BOX FILTERS

OPTIONAL FILTERS

20 INCH HIGH CURB/RAIL COMBINATION USED ON UNITS WITH 20" BLOWERS

CONDENSER INFORMATION

MODEL	WEIGHT #	TONNAGE	CC	DD	EE
E3-G18	15 TON	5 TON	32-13/16	76-3/16	70-7/8
E4-920	15 TON	5 TON	32-13/16	97-3/16	91-15/16

CELBEEK EVAPORATIVE COOLING UNIT

MODEL	TONNAGE RANGE	TOT. WEIGHT MEDIA SIZE & QTY	NOZZLES	MAX. FLOW RATE
E3-G18	15 TON	15 TON	38" x 43" x 12"	35
E4-920	15 TON	15 TON	45" x 54" x 12"	42

OPTIONAL MIXING BOX FILTERS

MODEL	WEIGHT #	TONNAGE	CC	DD	EE
E3-G18	15 TON	5 TON	32-13/16	76-3/16	70-7/8
E4-920	15 TON	5 TON	32-13/16	97-3/16	91-15/16

CONDENSER INFORMATION

MAX. EVAP WATER PRESSURE = 50 PSI @ 70 DEG F