

OUTSIDE SIDE DISCHARGE MOD PACKAGE UNIT, HEATING COIL, V-BANK FILTER, LPD EVAPORATIVE COOLER INTAKE, SCREEN INTAKE AND OPTIONAL MIXING BOX

SYBLPREF08BCCSM-HWU
REV 42, 06/15/2015

CONDENSER INFORMATION

MODEL	WEIGHT #1	TONNAGE #2	CC	DD	EE
2 TON-G10	119 LBS	2 TON	26-5/16	56-1/16	52-3/8
3 TON-G10	134 LBS	3 TON	33-5/16	63-1/16	59-3/8
5 TON-G10	253 LBS	3 TON	33-5/16	63-1/16	59-3/8
5 TON-G10	302 LBS	5 TON	2.5 TON	32-13/16	62-9/16
5 TON-G12	197 LBS	5 TON	N/A	32-13/16	62-9/16
7.5 TON-G12	197 LBS	5 TON	N/A	32-13/16	62-9/16
7.5 TON-G12	394 LBS	5 TON	3.2-13/16	69-9/16	65-7/8
5 TON-G15	197 LBS	5 TON	N/A	32-13/16	62-9/16
5 TON-G15	197 LBS	5 TON	N/A	32-13/16	62-9/16
7.5 TON-G15	302 LBS	5 TON	3.2-13/16	69-9/16	65-7/8
8 TON-G15	331 LBS	3 TON	5 TON	33-5/16	71-11/16
10 TON-G15	394 LBS	5 TON	5 TON	32-13/16	69-9/16
10 TON-G18	394 LBS	5 TON	5 TON	32-13/16	76-3/16
10 TON-G18	394 LBS	5 TON	5 TON	32-13/16	97-3/16
10 TON-G18	394 LBS	5 TON	5 TON	32-13/16	97-3/16

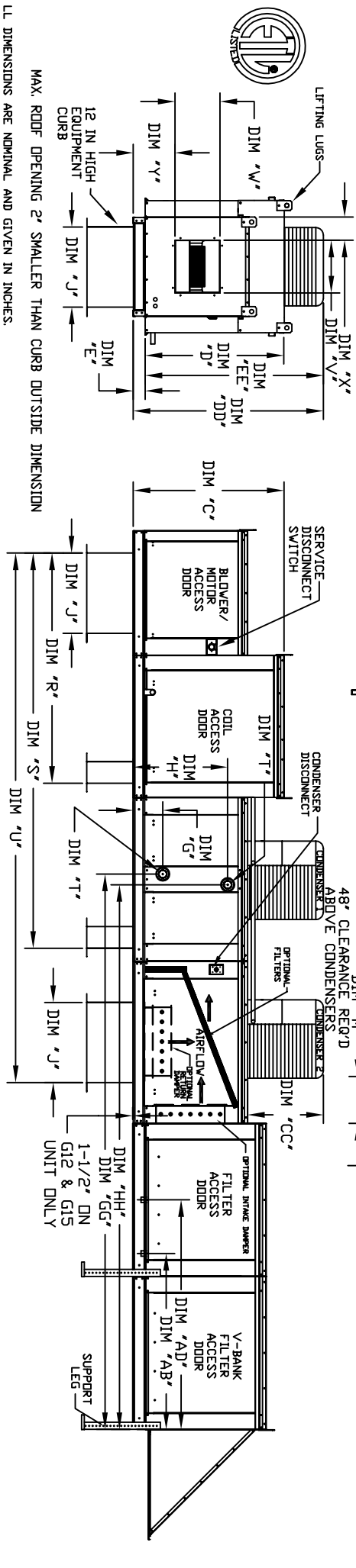
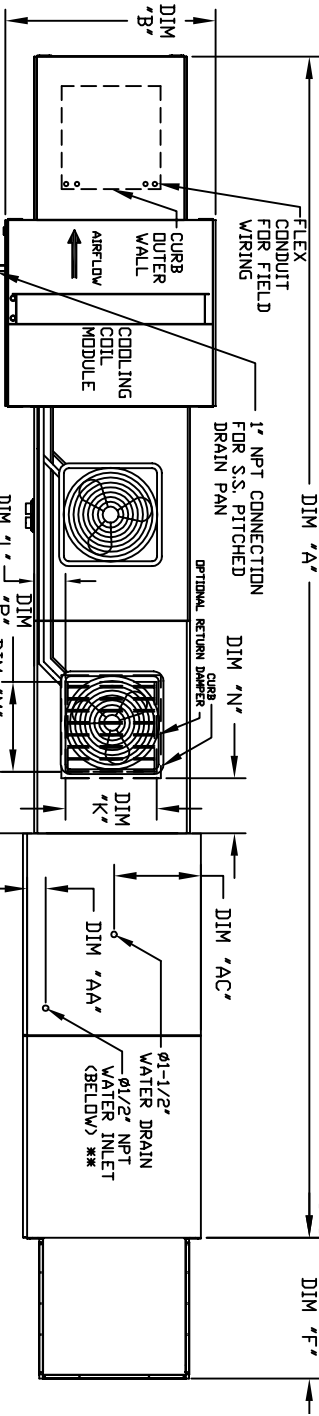

LL DIMENSIONS ARE NOMINAL AND GIVEN IN INCHES.

MAX. ROOF OPENING 2\"/>

MODEL	UNIT DIMENSIONS																TOTAL CAPACITY		PIPE CONNECTION		STEAM		DISCHARGE OPENING												TONNAGE RANGE		WATER INLET DRAIN OPENING																	
	A	B	C	D	E	F	G	H	I	J	K	L	M	N	P	R	S	U	V	W	X	Y	Z	AA	AB	AC	AD	AE	AF	AG	AH	AI	AJ	AK	AL	AM	AN	AO	AP	AQ	AR	AS	AT	AU	AV	AW	AX	AY	AZ	MIN	MAX	AA	AB	AC
G10	223-3/8	39-3/8	42-3/4	39	3-3/4	30-5/16	21	14	8	14	12-1/2	18	65-13/16	107-15/16	140-7/8	13-1/4	11-1/2	6-3/8	11-7/8	2	5 Ton	4-1/2	38-1/2	18	48-1/4	G10	16x20x2\"/>																											

MODEL TOTAL WEIGHT

MODEL	STEAM	HEATING COIL	EVAPORATIVE COOLING UNIT	MAX FLOW RATE
G10	1220 LBS	1660 LBS	1660 LBS	50 GPM
G12	1690 LBS	2020 LBS	2020 LBS	50 GPM
G15	1690 LBS	2020 LBS	2020 LBS	50 GPM
G18	1690 LBS	2020 LBS	2020 LBS	50 GPM
G20	1690 LBS	2020 LBS	2020 LBS	50 GPM

OPTIONAL MIXING BOX FILTERS

MODEL	STEAM	HEATING COIL	EVAPORATIVE COOLING UNIT	MAX FLOW RATE
G10	1220 LBS	1660 LBS	1660 LBS	50 GPM
G12	1690 LBS	2020 LBS	2020 LBS	50 GPM
G15	1690 LBS	2020 LBS	2020 LBS	50 GPM
G18	1690 LBS	2020 LBS	2020 LBS	50 GPM
G20	1690 LBS	2020 LBS	2020 LBS	50 GPM

STEAM COIL MODULE

MODEL	STEAM	HEATING COIL	EVAPORATIVE COOLING UNIT	MAX FLOW RATE
G10	1220 LBS	1660 LBS	1660 LBS	50 GPM
G12	1690 LBS	2020 LBS	2020 LBS	50 GPM
G15	1690 LBS	2020 LBS	2020 LBS	50 GPM
G18	1690 LBS	2020 LBS	2020 LBS	50 GPM
G20	1690 LBS	2020 LBS	2020 LBS	50 GPM

#ADD CONDENSING UNIT WEIGHT TO WEIGHT IN TABLES ABOVE