

MODULAR OUTDOOR DOWN DISCHARGE HEATER PACKAGED UNIT WITH COOLING, V-BANK, MIXING BOX AND SCREEN INTAKE

STV/BRE/SAC/CDP-49U  
REV#2 06/15/2015

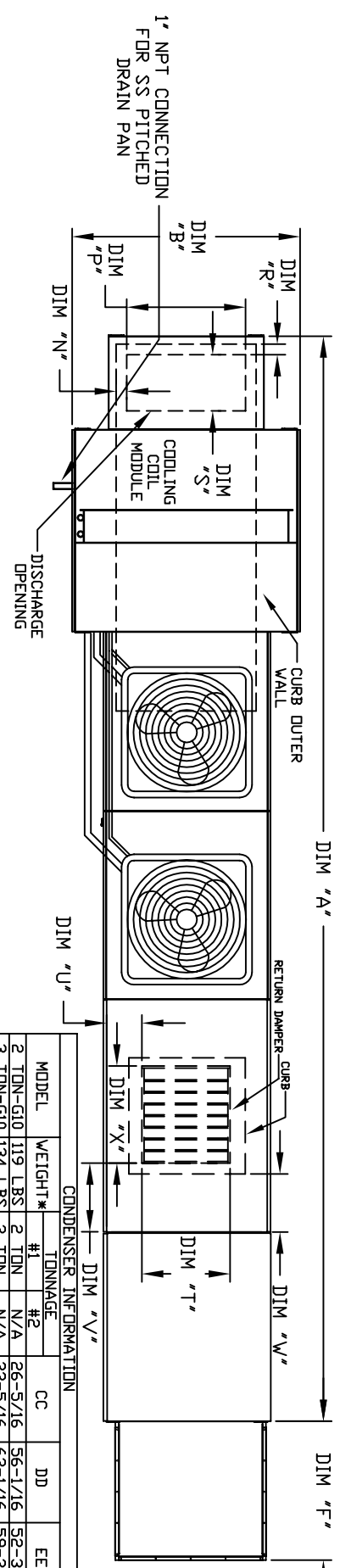

48 IN CLEARANCE REQUIRED ABOVE CONDENSERS

CONDENSER 1  
CONDENSER 2

OPTIONAL FILTERS  
INTAKE DAMPER

R410A REFRIGERANT

CONDENSER INFORMATION		CC	DD	EE
MODEL	WEIGHT *	#1	#2	
2 TON-G10	119 LBS	2 TON	N/A	26-5/16 56-1/16 52-3/8
3 TON-G10	134 LBS	3 TON	N/A	33-5/16 63-1/16 59-3/8
4 TON-G10	153 LBS	4 TON	N/A	40-1/8 70-1/8 66-1/4
5 TON-G10	177 LBS	5 TON	N/A	47-1/8 77-1/8 73-1/4
6 TON-G10	202 LBS	6 TON	N/A	54-1/8 84-1/8 80-1/4
7.5 TON-G15	197 LBS	5 TON	N/A	32-13/16 69-9/16 65-7/8
8 TON-G15	234 LBS	5 TON	N/A	33-5/16 71-11/16 68
10 TON-G15	394 LBS	5 TON	N/A	32-13/16 69-9/16 65-7/8
10 TON-G18	394 LBS	5 TON	N/A	32-13/16 69-9/16 65-7/8
10 TON-G18	394 LBS	5 TON	N/A	32-13/16 69-9/16 65-7/8
10 TON-G20	394 LBS	5 TON	N/A	32-13/16 69-9/16 65-7/8

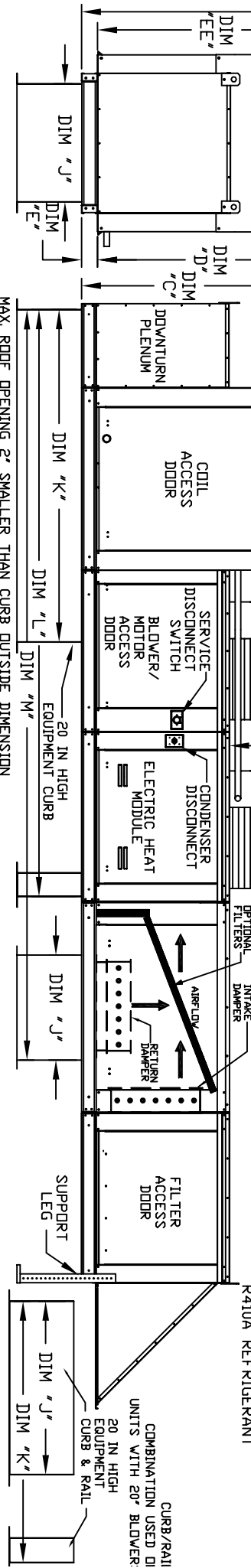

ALL DIMENSIONS ARE NOMINAL AND GIVEN IN INCHES.  
MAX. ROOF OPENING 2" SMALLER THAN CURB OUTSIDE DIMENSION

MODEL	WEIGHT	UNIT DIMENSIONS																											
		A	B	C	D	E	F	G	H	I	J	K	L	M	N	O	P	Q	R	S	T	U	V	W	X	Y	Z		
E1-G10	1215 LBS	209-1/2	39-3/8	42-3/4	39	3-3/4	22-3/8	21	71	131-5/8	163-1/16	6-1/8	13-7/8	3-1/4	11-1/2	14	8	14	14	14	14	14	14	12-1/2	18	18	24	24	30
E2-G15	1670 LBS	223-1/2	49-3/8	47-3/4	44	3-3/4	30-5/16	31	79	145-5/8	182-1/16	6-7/8	18-3/8	3	18	18	18	18	18	18	18	18	18	18	18	24	24	30	30
E3-G18	2025 LBS	234-1/2	54-3/8	56-3/8	51-1/8	5-1/4	34-3/16	35	84	150-5/8	190-1/16	8-7/8	22-3/8	3	18	18	18	18	18	18	18	18	18	18	18	24	24	30	30
E4-G20	3225 LBS	292-7/8	60-7/16	64-3/8	59-1/8	5-1/4	47-1/4	42	115-3/16	199-7/8	247-13/16	5-1/4	31-1/2	1-13/16	23-1/2	33	10	11	11	11	11	11	11	11	11	11	11	11	11

UNIT INFORMATION

MODEL	TONNAGE RANGE	FILTER SIZE & QTY	MAX. FILTER VELOCITY
E1-G10	2 Ton	20"x25"x2" (3)	@3600 CFM = 418 FPM
E2-G15	5 Ton	16"x20"x2" (8)	@6500 CFM = 464 FPM
E3-G18	10 Ton	20"x25"x2" (8)	@8000 CFM = 348 FPM
E4-G20	10 Ton	16"x20"x2" (15)	@13000 CFM = 495 FPM

OPTIONAL MIXING BOX FILTERS

FILTER SIZE & QTY
10"x16"x2" (5)
20"x25"x2" (2), 16"x25"x2" (1)
15"x20"x2" (4), 15"x15"x2" (2)
18"x25"x2" (4), 16"x20"x2" (2)

WARRANTY INFORMATION: LIMITED WARRANTY THROUGH THE MANUFACTURER'S WARRANTY.